

NATIONAL ENGINEERING COLLEGE

(An Autonomous Institution – Affiliated to Anna University Chennai)

K.R.NAGAR, KOVILPATTI – 628 503

www.nec.edu.in

REGULATIONS - 2015



**DEPARTMENT OF
MECHANICAL ENGINEERING**

**CURRICULUM AND SYLLABI OF
M.E. – ENERGY ENGINEERING**

SEMESTER – I

S. No.	Course Category	Course Code	Course Title	L	T	P	C	Question pattern [®]
THEORY COURSES								
1.	PCC	15EN11C	Advanced Thermal Engineering	3	2	0	4	A
2.	PCC	15EN12C	Renewable Energy Sources Conversion and Technology	3	0	0	3	A
3.	PCC	15EN13C	Energy Conservation in Thermal and Electrical Utilities	3	0	0	3	C
4.	PCC	15EN14C	Instrumentation and Control for Energy Systems	3	0	0	3	B
5.	PCC	15EN15C	Industrial Energy Management	3	0	0	3	B
6.	PEC		Elective – I	3	0	0	3	
PRACTICAL COURSES								
7.	PCC	15EN16C	Energy Laboratory-I	0	0	4	2	
Total				18	2	4	21	

SEMESTER – II

S.No.	Course Category	Course Code	Course Title	L	T	P	C	Question pattern [®]
THEORY COURSES								
1.	PCC	15EN21C	Solar Energy and Utilization	3	0	0	3	B
2.	PCC	15EN22C	Wind Energy Technology	3	0	0	3	B
3.	PCC	15EN23C	Bio Energy Engineering	3	0	0	3	B
4.	PEC		Elective – II	3	0	0	3	
5.	PEC		Elective - III	3	0	0	3	
PRACTICAL COURSES								
6.	PCC	15EN24C	Energy Laboratory-II	0	0	4	2	
7.	PCC	15EN25C	Mini Project*	0	0	3	1	
8.	PCC	15EN26C	Research Paper and Patent Review – Seminar	0	0	4	2	
Total				15	0	8	19	

SEMESTER – III

S. No.	Course Category	Course Code	Course Title	L	T	P	C	Question pattern [⊕]
THEORY COURSES								
1.	OEC		Elective - IV	3	0	0	3	
2.	PEC		Elective – V	3	0	0	3	
3.	PEC		Elective – VI	3	0	0	3	
4.	PEC		Elective - VII	3	0	0	3	
PRACTICAL COURSES								
5.	PCC	15EN31C	Project Work Phase I	0	0	12	6	
Total				12	0	12	18	

SEMESTER – IV

S. No.	Course Category	Course Code	Course Title	L	T	P	C	Question pattern [⊕]
PRACTICAL COURSES								
1.	PCC	15EN41C	Project Work Phase II	0	0	24	12	
TOTAL				0	0	24	12	

TOTAL CREDITS TO BE EARNED FOR THE AWARD OF THE DEGREE - 71

* - *Studies to demonstrate simple basic concepts and aspects of various Energy Technologies have to be carried out by the students in the II semester which will be evaluated by the Internal Examiner.*

PROGRAMME ELECTIVE COURSES

S. No.	Course Category	Course Code	Course Title	L	T	P	C	Question pattern [⊕]
THEORY COURSES								
1.	PEC	15EN01E	Electrical Technology for Energy Systems	3	0	0	3	B
2.	PEC	15EN02E	Thermal Energy Systems for Electrical Engineers	3	0	0	3	B
3.	PEC	15EN03E	Advanced Power Plant Engineering	3	0	0	3	B
4.	PEC	15EN04E	Advanced Thermal Storage Technologies	3	0	0	3	B
5.	PEC	15EN05E	Advances In Metallurgical Engineering	3	0	0	3	A
6.	PEC	15EN06E	Alternative Fuels	3	0	0	3	B
7.	PEC	15EN07E	Analytical Chemistry	3	0	0	3	A
8.	PEC	15EN08E	Cogeneration and Waste Heat Recovery Systems	3	0	0	3	B
9.	PEC	15EN09E	Coordination Chemistry	3	0	0	3	A
10.	PEC	15EN10E	Design and Optimization of Energy Systems	3	0	0	3	A
11.	PEC	15EN11E	Design of Heat Exchangers	3	0	0	3	B
12.	PEC	15EN12E	Energy Efficient Buildings	3	0	0	3	C
13.	PEC	15EN13E	Energy System Modeling and Project Management	3	0	0	3	B
14.	PEC	15EN14E	Fluidized Bed Systems	3	0	0	3	B
15.	PEC	15EN15E	Fuel cells and Hydrogen Energy	3	0	0	3	B
16.	PEC	15EN16E	Hydro Power Technology	3	0	0	3	B
17.	PEC	15EN17E	Material Sciences and Engineering	3	0	0	3	A
18.	PEC	15EN18E	Materials for Energy Applications	3	0	0	3	A
19.	PEC	15EN19E	Nuclear Engineering	3	0	0	3	B
20.	PEC	15EN20E	Nanotechnology and Nano Electronics	3	0	0	3	A
21.	PEC	15EN21E	Physical Organic Chemistry	3	0	0	3	A
22.	PEC	15EN22E	Solar Architecture	3	0	0	3	B
23.	PEC	15EN23E	Solar Photovoltaic Power Plants: Planning, Design and Balance of Systems	3	0	0	3	D
24.	PEC	15EN24E	Solar Refrigeration and Air-Conditioning	3	0	0	3	B
25.	PEC	15EN25E	Spectroscopic Methods in Chemistry	3	0	0	3	A
26.	PEC	15EN26E	Waste Management and Energy Recovery	3	0	0	3	D
27.	PEC	15EN27E	Research Methodology	3	0	0	3	B

S. No.	Course Category	Course Code	Course Title	L	T	P	C	Question pattern [⊕]
28.	PEC	15EN28E	Design of Experiments	3	0	0	3	B
29.	OEC		Courses offered by other PG programmes					

⊕

Question pattern	1 mark	2 marks	4 marks	10 marks	12 marks	16 marks	20 marks	Total
A	-	-	-	-	--	-	1 Qn Compulsory & 4 Qns (either or type)	100
B	-	10	-	-	--	1 Qn Compulsory & 4 Qns (either or type)	--	100
C	10	-	10 out of 12	1 Qn Compulsory & 4 Qns (either or type)	--	--	--	100
D	10	10	5 out of 6	1 Qn Compulsory & 4 Qns (either or type)	--	--	--	100
E	-	10	5 out of 6	-	1 Qn Compulsory & 4 Qns (either or type)	--	--	100

FORMAT FOR COURSE CODE

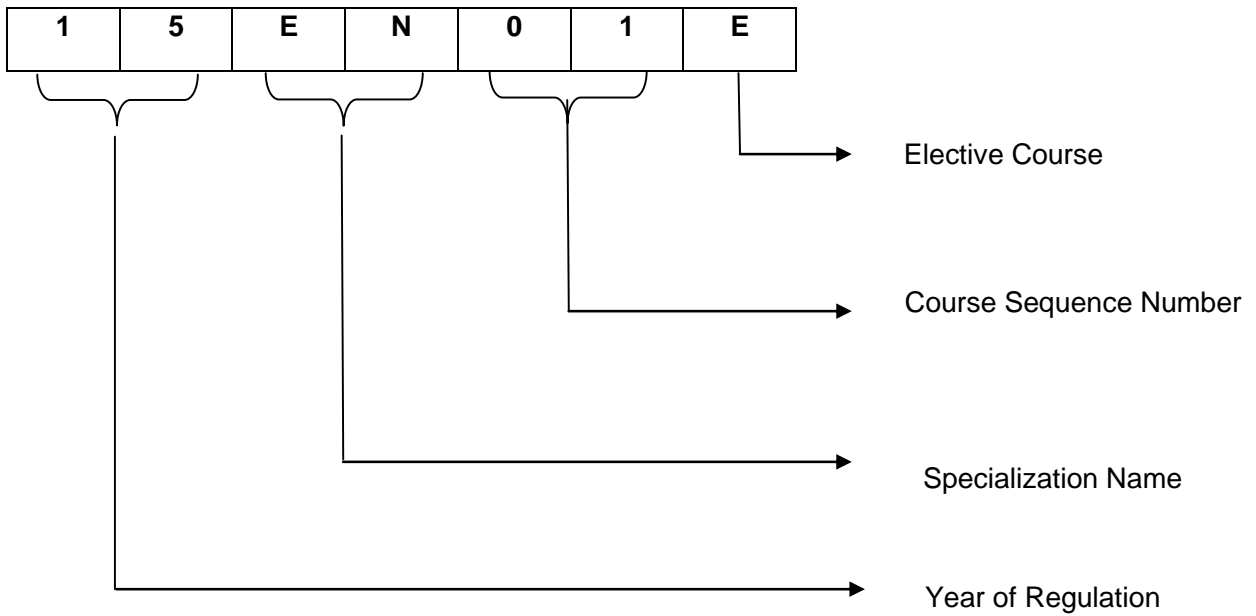
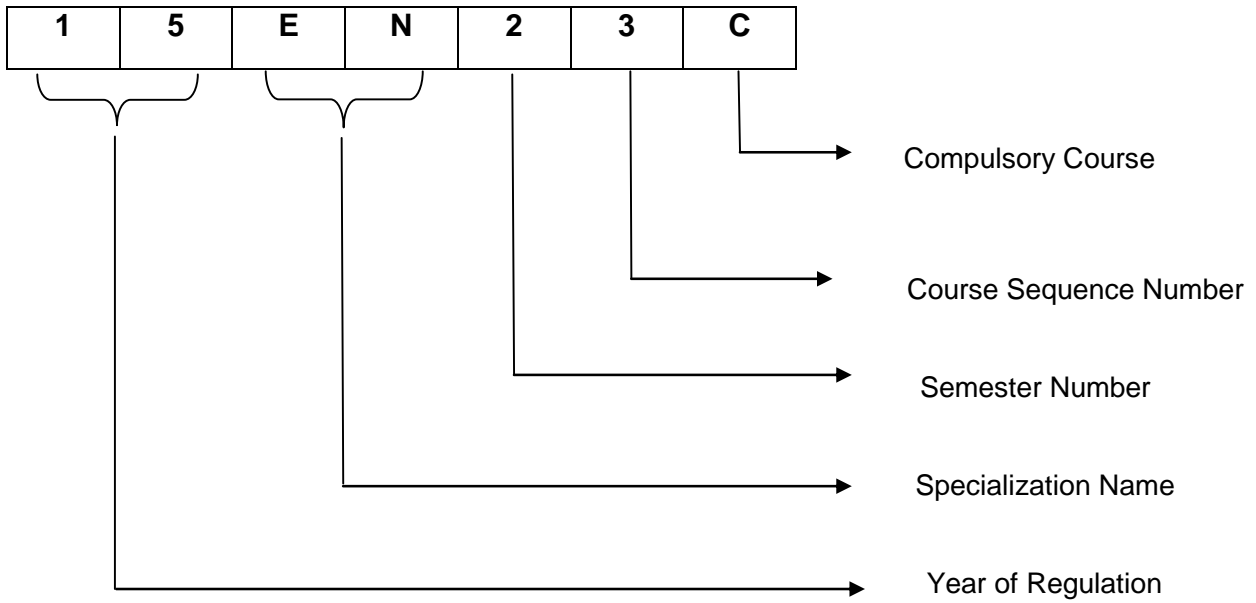

15EN11C ADVANCED THERMAL ENGINEERING

L T P C
3 2 0 4

COURSE OUTCOMES

Upon completion of this course, the students will be able to

- CO 1 : apply second law of thermodynamics for the various concepts and thermodynamic relations. (K3, A4)
- CO 2 : elucidate the three modes of heat transfer for the various applications. (K2,S1,A2)
- CO 3 : design and analyze the performance of heat exchanges. (K4, A4)

UNIT I REVIEW OF THERMODYNAMICS AND SECOND LAW ANALYSIS 15

Basic concepts of thermodynamics; irreversibility; Review of basic laws of thermodynamics and their consequences; Concept of Exergy and Entropy; Exergy for closed system; Entropy generation; entropy balance for closed system; behavior of gases; Equations of state.

UNIT II THERMODYNAMIC RELATIONS 15

Phase equilibrium; phase rule without chemical reaction; chemical potential of ideal gases; T-ds equations for simple compressible systems; Helmholtz and Gibbs functions; Maxwell relations; generalized relations for changes in enthalpy; entropy and internal energy; equations for specific heats; Clausius clapeyron equation; Joule-Thomson and Joule coefficients; applications of thermodynamic relations.

UNIT III CONDUCTION HEAT TRANSFER 15

Review of the basic laws of conduction; One dimensional steady state conduction with variable thermal conductivity and with internal distributed heat source; Extended surfaces-review and design considerations; Two dimensional steady state conduction; Unsteady state conduction; solutions using Groeber's and Heisler's charts for plates, cylinders and spheres suddenly immersed in fluids.

UNIT IV CONVECTION AND RADIATION HEAT TRANSFER 15

Review of convection and radiation heat transfer laws, Natural and forced convection; Heat transfer in turbulent flow; eddy heat diffusivity; Reynold's analogy between skin friction and heat transfer; von Karman; turbulent flow through circular tubes; Review of radiation principles; diffuse surfaces and the Lambert's Cosine law; Radiation through non-absorbing media; Hottel's method of successive reflections.

UNIT V HEAT EXCHANGERS 15

Different types of heat exchangers, arithmetic and logarithmic mean temperature differences, heat transfer coefficient for parallel, counter and cross flow type heat exchanger; effectiveness of heat exchanger, N.T.U. method, fouling factor. Constructional and manufacturing aspects of Heat Exchangers.

L: 45 T: 30 TOTAL: 75 PERIODS

REFERENCES

1. Moran MJ & Shapiro HM, "Fundamentals of Engineering Thermodynamics", John Wiley, 2012
2. A.Faghri, JHowell, Y Zhang, "Advanced Heat and Mass Transfer", Global Digital Press, 2010
3. P.K.Nag, "Engineering Thermodynamics", 4th Edition, Tata McGraw-Hill, 2008
4. Y.A Cengel, M.A.Boles, "Thermodynamics: An Engineering Approach", 6th Edition, McGraw-Hill Series 2007
5. Bejan,A., "Advanced Engineering Thermodynamics" 3rd Edition, John Wiley and Cons, 2006.
6. Roger Gordon & Yon Mayhew "Engineering Thermodynamics Work and Heat Transfer", Addison-Wesley, 2001
7. Frank Kreith., "The CRC handbook of Thermal Engineering", Springer, 2000.
8. Hans Dieter Baehr, Karl Stephan, "Heat and Mass Transfer", Springer, 2011.

15EN12C RENEWABLE ENERGY SOURCES CONVERSION AND TECHNOLOGY

**L T P C
3 0 0 3**

COURSE OUTCOMES

Upon completion of this course, the students will be able to

- CO 1 : recognize the basic principles of concept of various forms of renewable energy (k3)
- CO 2 : develop knowledge on solar radiation principles and its conversion (k2)
- CO 3 : interpret the concepts of extraction of Wind Energy, various Bio-Energy Conversion techniques (k4)
- CO 4 : familiarize with the concepts of Hydrogen Energy and other forms of Renewable Energy (k3)

UNIT I SOLAR ENERGY 9

Solar radiation its measurements and prediction - solar thermal flat plate collectors concentrating collectors – applications - heating, cooling, desalination, power generation, drying, cooking etc - principle of photovoltaic conversion of solar energy, types of solar cells and fabrication. Photovoltaic applications: battery charger, domestic lighting, street lighting, and water pumping, power generation schemes.

UNIT II WIND ENERGY 9

Atmospheric circulations – classification - factors influencing wind - wind shear – turbulence - wind speed monitoring - Betz limit - Aerodynamics of wind turbine rotor- site selection - wind resource assessment - wind energy conversion devices - classification, characteristics and applications. Hybrid systems - safety and environmental aspects.

UNIT III BIO-ENERGY 9

Biomass resources and their classification - chemical constituents and physicochemical characteristics of biomass - Biomass conversion processes - Thermo chemical conversion: direct combustion, gasification, pyrolysis and liquefaction - biochemical conversion: anaerobic digestion, alcohol production from biomass - chemical conversion process: hydrolysis and hydrogenation. Biogas - generation - types of biogas Plants- applications

UNIT IV HYDROGEN AND FUEL CELLS 9

Thermodynamics and electrochemical principles - basic design, types, and applications - production methods - Biophotolysis: Hydrogen generation from algae biological pathways - Storage gaseous, cryogenic and metal hydride and transportation. Fuel cell – principle of working - various types - construction and applications.

UNIT V OTHER TYPES OF ENERGY 9

Ocean energy resources - principles of ocean thermal energy conversion systems - ocean thermal power plants - principles of ocean wave energy conversion and tidal energy conversion – hydropower – site selection, construction, environmental issues - geothermal energy - types of geothermal energy sites, site selection, and geothermal power plants.

L: 45 TOTAL: 45 PERIODS

REFERENCES

1. Sukhatme S.P., “Solar Energy”, Tata McGraw Hill, 2008.
2. Mukund R. Patel, “Wind and Solar Power Systems”, CRC Press, 1999.
3. Hart, A.B., and Womack, G. J., “Fuel Cells: Theory & Applications”, Prentice Hall, 1997.
4. Godfrey Boyle, “Renewable Energy, Power for a Sustainable Future”, Oxford University Press, U.K, 1996.
5. Veziroglu, T.N., “Alternative Energy Sources”, Vol.5 and 6, McGraw-Hill, 1990
6. Twidell, J.W. and Weir, A., “Renewable Energy Sources”, EFN Spon Limited, 1986.
7. Khandelwal K.C, Mahdi S.S., “Biogas Technology” - A Practical Handbook, Tata McGraw Hill, 1986.
8. Kreith, F and Kreider, J. F.,” Principles of Solar Engineering”, McGraw-Hill, 1978

15EN13C ENERGY CONSERVATION IN THERMAL AND ELECTRICAL UTILITIES L T P C
3 0 0 3

COURSE OUTCOMES

Upon completion of this course, the students will be able to

- CO 1 : recognize the combustion process and able to calculate the amount of air required for combustion of solid, liquid and gaseous fuels. (K2, S1)
- CO 2 : evaluate the performance of boilers and suggest energy conservation strategies. (K4, S3)
- CO 3 : workout and suggest prevention techniques for energy losses in steam circuits. (K4, A3)
- CO 4 : carryout performance evaluation of electric motors, fans and pumps. Further, identify energy conservation opportunities. (K3,A2)
- CO 5 : identify the new generation lightings and operating principles of energy efficiency devices. (K3, A2)

UNIT I FUELS AND COMBUSTION 9

Introduction to fuels - properties of fuel oil, coal and gas - storage, handling and preparation of fuels - principles of combustion - combustion of oil, coal and gas. - draft system – combustion controls - Agro-residue/biomass handling, preparation and combustion.

UNIT II BOILERS AND COGENERATION 9

Combustion in boilers - performances evaluation – direct and indirect method- analysis of losses - feed water treatment, blow down - boiler efficiency calculation - energy conservation opportunities. Cogeneration - principles & operation – Power Ratio - economics of cogeneration scheme – classification - heat balance - steam turbine efficiency.

UNIT III STEAM SYSTEM 09

Properties of steam - assessment of steam distribution losses, steam leakages, steam trapping - condensate and flash steam recovery system - identifying opportunities for energy savings. Steam utilization - Performance assessment - thermo-compressor, steam pipe insulation - condensate pumping - steam dryers.

UNIT IV ELECTRIC MOTORS, FANS AND PUMPS 9

Electric motor types - losses in induction motors - motor efficiency, factors affecting motor performance - energy saving opportunities with energy efficient motors. Fans and Pumps – types - performance evaluation - efficient system operation - flow control strategies and energy conservation opportunities.

UNIT V LIGHTING SYSTEM AND ENERGY EFFICIENCY DEVICES 9

Lighting sources - choice of lighting - luminance requirements and energy conservation avenues. New generation luminaries - Light Emitting Diodes (LEDs) - high efficiency street lighting. Maximum demand controllers – Automatic power factor controllers – Soft starters with energy saver - electronic ballast - occupancy sensors – energy efficient lighting controls.

L: 45 TOTAL: 45 PERIODS

REFERENCES

1. Amlan Chakrabarti, “Energy Engineering and Management”, Prentice Hall India, 2011
2. Beggs, Clive, “Energy – Management, Supply and Conservation”, Taylor and Francis, 2nd Edition, 2009.
3. Handbook on Energy Efficiency, TERI, New Delhi, 2009.
4. Smith C.B., “Energy Management Principles”, Pergamon Press, 2006.
5. White L. C., “Industrial Energy Management and Utilization”, Hemisphere Publishers, 2002.
6. Trivedi P.R. and Jolka K.R., “Energy Management”, Common Wealth Publication, 2002.
7. Bureau of energy efficiency – Hand outs New Delhi.

15EN14C INSTRUMENTATION AND CONTROL FOR ENERGY SYSTEMS L T P C
3 0 0 3

COURSE OUTCOMES

Upon completion of this course, the students will be able to

- CO 1 : describe the basic characteristics of instruments for measurement of specific thermo physical properties and its applications. (k3)
- CO 2 : recognize the advanced measurement techniques (k2)
- CO 3 : interpret the concepts of system control and process parameters (k4)

UNIT I MEASUREMENT CHARACTERISTICS 9

Instrument classification - characteristics of instruments – static and dynamic - experimental error analysis - systematic and random errors - statistical analysis – uncertainty - experimental planning and selection of measuring instruments - reliability of instruments

UNIT II MEASUREMENT OF PHYSICAL QUANTITIES 9

Measurement of thermo – physical properties, instruments for measuring temperature - pressure and flow

UNIT III ADVANCE MEASUREMENT TECHNIQUES 9

Shadow graph – Schlieren – Interferometer - Laser doppler anemometer - Hot wire anemometer, Heat flux sensors - Telemetry in measurement.

UNIT IV CONTROL SYSTEMS 9

Introduction - controllability, observability, Continuous and discrete process Controllers – Control Mode – Two – Step mode – Proportional Mode – Derivative Mode – Integral Mode – PID Controllers – Programmable Logic Controllers - Microprocessor PC based control applications.

UNIT V DATA ACQUISITION AND PROCESSING 9

Multi Channel Data acquisition system – Architecture of data acquisition and computer control system - Compact Data loggers – Sensor based, Computerized data systems - Micro – computer interfacing - Intelligent instruments in use.

L: 45 TOTAL: 45 PERIODS

REFERENCES

1. Manabendra Bhuyan, “Intelligent Instrumentation”, CRC Press, 209
2. Morris A.S., “Principles of Measurements and Instrumentation”, Butterworth-Heinemann, 2003
3. Ernest Doebelin, “Measurement Systems”, McGraw-Hill, 2003
4. Singh. S. K., “Industrial Instrumentation and Control”, Tata McGraw-Hill, 2003
5. Holman J.P. “Experimental methods for Engineers, 7th Edition”, McGraw-Hill, 2001
6. Rangan., “Instrumentation Devices and Systems”, Tata McGraw-Hill Education, 2001
7. John G. Webster., “The Measurement, Instrumentation, and Sensors Handbook”, Springer, 1999

15EN15C INDUSTRIAL ENERGY MANAGEMENT

L T P C
3 0 0 3

COURSE OUTCOMES

Upon completion of this course, the students will be able to

- CO 1 : realize the present energy scenario and the need for energy conservation and various energy conservation measures (K2, A2)
- CO 2 : familiarize with various energy policies (National and International) & standards. (K2, A1)
- CO 3 : comprehend the concepts of recovery system and perform energy analysis.(K2,A3)
- CO 4 : conduct energy audit and optimize energy requirements. (K3, A4)
- CO 5 : recognize the economics of energy conservation schemes in industrial energy management systems (k2, A1)

UNIT I INTRODUCTION 9

Energy Scenario - world and India. Energy Resources Availability in India. Energy consumption pattern. Energy conservation potential in various Industries and commercial establishments. Energy intensive industries - an overview. Energy conservation and energy efficiency – needs and advantages. Energy Conservation Act.

UNIT II ENERGY POLICIES 9

National energy policy in the last plan periods, Energy use and Energy supply, Overview of renewable energy policy and the Five Year Plan programmes, Basic concept of Input-Output analysis, Concept of energy multiplier and implication of energy multiplier for analysis of regional and national energy policy- Carbon Trading- Renewable Energy Certification - CDM

UNIT III WASTE HEAT RECOVERY 9

Recuperators, regenerators, heat pipes, heat pumps. Cogeneration - concept, options (steam/gas turbines/diesel engine based), selection criteria, control strategy. Heat exchanger networking - concept of pinch, target setting, problem table approach, composite curves. Demand side management.

UNIT IV ENERGY CONSERVATION AND AUDITING 9

Definition, need, and types of energy audit; Energy management (audit) approach: Understanding energy costs, bench marking, energy performance, matching energy use to requirement, maximizing system efficiencies, optimizing the input energy requirements; Fuel & energy substitution. Energy auditing - types, methodologies, barriers. Energy audit instruments; Duties and responsibilities of energy managers and auditors - Energy audit questionnaire.

UNIT V ENERGY MANAGEMENT 9

Organizational background desired for energy management persuasion, motivation, publicity role, industrial energy management systems. Energy monitoring and targeting - Elements, data, information analysis and techniques – Energy consumption, production, cumulative sum of differences (CUSUM). Energy Management Information Systems (EMIS). Economics of various energy conservation schemes – Energy policy and energy labeling.

L: 45 TOTAL: 45 PERIODS

REFERENCES

1. Steve Doty, Wayne C. Turner “Energy Management Handbook”, 7th Edition, the Fairmont Press, Inc., 2009.
2. F Kreith, D.Y.Goswami, “Energy management and conservation handbook”, CRC Press, 2008.
3. “Industrial Energy Conservation Manuals”, MIT Press, Mass, 2007.
4. YP Abbi and Shashank Jain. “Handbook on Energy Audit and Environment Management”, TERI Publications, 2006.
5. R Loulou, P R Shukla and A Kanudia, “Energy and Environment Policies for a sustainable Future”, Allied Publishers Limited, New Delhi, 1997
6. Guide book for “National Certification Examination for Energy Managers and Energy Auditors” (Could be downloaded from www.energymanagertraining.com)

15EN16C

ENERGY LABORATORY-I

L T P C

0 0 4 2

COURSE OUTCOMES

Upon completion of this course, the students will be able to

- CO 1: carry out the performance analysis and optimization of energy utilities
- CO 2: familiarize with the parameters that affect the performance of energy systems
- CO 3: analyze the characteristics of various fuels

RENEWABLE ENERGY

36

1. Performance testing of Solar Water Collector
2. Characteristics of Solar photovoltaic devices
 - Investigation of PV Characteristics – Amorphous Silicon.
 - Investigation of PV Characteristics – Amorphous Silicon – Shadow effect
 - Comparative Performance Analysis of Mono & Poly Crystalline Silicon PV cell
3. Testing of Gasifier
4. Properties of Fuels
 - Determination of Flash and Fire Point using Pensky Marten Apparatus
 - Determination of Flash and Fire Point using Abel Apparatus
 - Determination of Density and Dynamic Viscosity of oil using Redwood Viscometer
5. Solar Radiation measurement
6. Performance testing of Solar Air Heater
7. Performance testing of Solar Still
8. Performance Study on Concentric Collectors
9. Study of biogas plant

ENERGY CONSERVATION

18

1. Performance Test of Parallel flow and Counter flow Heat Exchanger
2. Energy consumption measurement of lighting systems
3. Performance Test on Vapour Compression Refrigeration Systems
4. Performance Test on Air conditioning Systems

ADVANCED ENERGY SYSTEMS

06

1. Thermal Storage Systems

P: 60 TOTAL: 60 PERIODS

15EN21C

SOLAR ENERGY AND UTILIZATION

L T P C
3 0 0 3

COURSE OUTCOMES

Upon completion of this course, the students will be able to

- CO 1 : predict and estimate solar energy potential and its availability (K4, A2)
- CO 2 : examine various collecting techniques of solar energy and its storage (K4)
- CO 3 : interpret PV technology principles and conversion of Solar energy into Electricity (K2, A1)
- CO 4 : reveal the economical and environmental merits of solar energy for variety of applications (K2, A2)

UNIT I SOLAR RADIATION

9

Source of radiation – Sun earth relationship- extra terrestrial radiation.– Atmospheric attenuation – Terrestrial radiation-radiation on a horizontal surfaces and inclined planes - relations between monthly, daily and hourly radiation and components of the radiations– solar charts – Critical radiation-Measurement of global, direct and diffuse solar radiation- pyroheliometer, pyrano meter, pyro geo meter, sunshine recorder – an overview of solar radiation data in India.

UNIT II SOLAR COLLECTORS

9

Design considerations – classification- Flat plate collectors-Temperature distributions- Heat removal rate- Useful energy gain – Losses in the collectors - efficiency of flat plate collectors – selective surfaces – tubular solar energy collectors– testing of flat plate collectors. Concentric collectors - Limits to concentration – concentrator mounting – tracking mechanism - performance analysis focusing solar concentrators: Heliostats.

UNIT III PHOTOVOLTAIC SYSTEMS

9

Conversion of Solar energy into Electricity - Photovoltaic Effect, Photovoltaic material - Solar Cell – Module – Silicon solar cell, Efficiency limits, Variation of efficiency with band-gap and temperature, Efficiency measurements, High efficiency cells, Recent developments in Solar Cells - PV systems - applications

UNIT IV ENERGY STORAGE

9

Sensible Heat Storage – Liquid media storage – Solid media storage – Latent heat storage - Phase change materials – Chemical storage

UNIT V INDUSTRIAL APPLICATIONS OF SOLAR HEAT

9

Solar Thermal Power Plant, Solar Desalination, Solar Water Heating, Solar Air Heating, Solar Drying, Solar Cooking, Solar Greenhouse technology: Fundamentals and applications.

L: 45 TOTAL: 45 PERIODS

REFERENCES

1. L D. Partain, L M. Fraas, “Solar Cells and Their Applications”, 2nd Edition, John Wiley and Sons, 2010
2. Soteris Kalogirou, “Solar Energy Engineering”, Academic Press, 2009
3. Sukhatme S P, “Solar Energy”, 3rd Edition, Tata McGraw-Hill Education, 2008
4. Duffie, J. A. and Beckman, W. A., “Solar Engineering of Thermal Processes”, 3rd Edition, Wiley, 2006
5. G. N. Tiwari, “Solar Energy Fundamentals, Design, Modelling and Applications”, Narosa Publishing House Private Limited, 2002
6. H.P. Garg and J. Prakash, “Solar Energy- Fundamentals & Applications”, Tata McGraw-Hill, 2000

15EN22C

WIND ENERGY TECHNOLOGY

L T P C
3 0 0 3

COURSE OUTCOMES

Upon completion of this course, the students will be able to

- CO 1 : comprehend the fundamentals of wind energy and its conversion system (K3)
- CO 2 : disseminate with the wind measurement techniques (k4)
- CO 3 : summarize the concepts of aerodynamics, wind farms and cycles (K4)
- CO 4 : analyze the economics of wind energy systems (K4)

UNIT I WIND CHARACTERISTICS AND RESOURCES 9

Characteristics of the Wind Resource- Characteristics of the Atmospheric Boundary Layer-Wind Data Analysis and Resource Estimation-Wind Turbine Energy Production Estimates Using Statistical Techniques-Regional Wind Resource Assessment-Wind Prediction and Forecasting-Wind Measurement and Instrumentation.

UNIT II AERODYNAMICS OF WIND TURBINES 9

One-dimensional Momentum Theory and the Betz Limit-Ideal Horizontal Axis Wind Turbine with Wake Rotation-Airfoils and General Concepts of Aerodynamics-Blade Design for Modern Wind Turbines-Performance Prediction-Blade Shape for Optimum Rotor with Wake Rotation-Generalized Rotor Design Procedure-Effect of Drag and Blade Number on Optimum Performance-Aerodynamics of Horizontal and Vertical Axis Wind Turbines

UNIT III MODERN WIND TURBINE CONTROL AND MONITORING SYSTEM 9

Details of Pitch and Yaw Systems- Protections & Safety Consideration in Wind turbines- Wind Turbine Monitoring- SCADA & Databases: Remote Monitoring and Generation Reports, Operation & Maintenance for Product Life Cycle, Balancing technique (Rotor & Blade).

UNIT IV CONCEPT OF WIND FARMS 9

Wind Farms - Site Preparation-Installation and Operation Issues - Wind Farms in Electrical Grids-Typical Grid-connected Turbine Operation. Environmental concerns: Pollution free power; Noise; birds; Aesthetics, Radio waves, interference, Rainfall,

UNIT V ECONOMICS ANALYSIS 9

Economic Assessment of Wind Energy Systems- Capital Costs of Wind Energy Systems- Operation and Maintenance Costs- Value of Wind Energy- Economic Analysis Methods- Wind Energy Market Considerations

L:45 TOTAL: 45 PERIODS

REFERENCES

1. T Burton, et.al, "Wind Energy Handbook", 2nd Edition, John Wiley and Sons, 2011
2. J.F. Manwell, et.al, "Wind Energy Explained", 2nd Edition, John Wiley and Sons, 2009
3. D. A. Spera, "Wind Turbine Technology: Fundamental concepts of Wind Turbine Engineering", 2nd Edition, ASME Press, 2009
4. William W. Peng, "Fundamentals of turbomachinery", John Wiley and Sons, 2008
5. Mukund. R. Patel, "Wind and solar power systems" 2nd Edition, Taylor & Francis, 2006

15EN23C

BIO ENERGY ENGINEERING

L T P C
3 0 0 3

COURSE OUTCOMES

Upon completion of this course, the students will be able to

CO 1 : classify the types of biomass and its surplus availability.(K4)

CO 2: analyze the bio-chemical energy conversion processes and technologies in terms of its technical competence and economic implications.(K3)

UNIT I INTRODUCTION 9

Biomass: types – advantages and drawbacks – Indian scenario – characteristics – carbon neutrality – conversion mechanisms – fuel assessment studies

UNIT II BIO METHANATION 9

Microbial systems – phases in biogas production – parameters affecting gas production – effect of additives on biogas yield – possible feed stocks. Biogas plants – types – design – constructional details and comparison – biogas appliances – Burner, illumination and power generation – effect on engine performance. Kinetics and mechanism - High rate digesters for industrial waste water treatment.

UNIT III COMBUSTION 9

Perfect, complete and incomplete – equivalence ratio – fixed Bed, fluid Bed – fuel and ash handling – steam cost comparison with conventional fuels. Briquetting: types of Briquetting – merits and demerits – feed requirements and preprocessing – advantages – drawbacks

UNIT IV GASIFICATION 9

Types – comparison – application – performance evaluation – economics – dual fuel engines – 100 % Gas Engines – engine characteristics on gas mode – gas cooling and cleaning train.

UNIT V PYROLYSIS AND CARBONIZATION 9

Pyrolysis-Types – process governing parameters – differential thermal analysis – differential scanning calorimetry – Typical yield rates. Effect of carbonisation temperature on yield and composition of charcoal- Industrial safety in carbonization.

L: 45 TOTAL: 45 PERIODS

REFERENCES

1. A.A. Vertès, N Qureshi, H Yukawa, “Biomass to biofuels: strategies for global industries”, John Wiley and Sons, 209
2. J.D. Wall, C.S. Harwood, A.L. Demain, “Bioenergy”, ASM Press, 2008
3. D.M. Mousdale, “Biofuels”, CRC Press, 2008
4. Nijaguna, B.T., “Biogas Technology”, New Age International Publishers Private Limited, 2006
5. Rezaian. J and N. P. Cheremisinoff, “Gasification Technologies, A Primer for Engineers and Scientists”, Taylor & Francis, 2005
6. IEEE Journals for Power, Energy, & Industry Applications

15EN24C

ENERGY LABORATORY-II

L T P C

0 0 4 2

COURSE OUTCOMES

Upon completion of this course, the students will be able to

CO 1: simulate and predict the performance of various energy utilities

CO 2: analyze the effect of constraints on the performance of energy systems

CO 3: model and simulate various energy systems to optimize the performance

I Cycle (using ANSYS)

24

Steady State Conductive Heat Transfer Analysis in a cubical block

Analysis of Thermal Mixed Boundary for an infinitely long block

Analysis of Transient Thermal Heat Conduction for an infinitely long block

Study of temperature distribution along a Straight rectangular stainless steel cooling fin

Determination of heat conducted by a Cooling Spine

Laminar Flow Analysis in a 2D Duct

Analysis of flow in a System of Pipes to compute the velocity distribution

II Cycle (using TRNSYS)

36

Performance analysis of Solar Flat Plate Collecting System

Performance analysis of Solar Evacuated Tube Collecting System

Performance analysis of Spiral Flow Solar Water Heating System

Performance analysis of Solar Air Heating System

Cooling tower Analysis

Performance analysis of Solar PV

P: 60 TOTAL: 60 PERIODS

15EN26C

RESEARCH PAPER AND PATENT REVIEW – SEMINAR

L T P C

0 0 4 2

The student will make at least two technical presentations on current topics related to the specialization. The same will be assessed by a committee appointed by the department. The students are expected to submit a report at the end of the semester covering the various aspects of his/her presentation together with the observation in industry visits.

P:60; TOTAL: 60 PERIODS

15EN01E

ELECTRICAL TECHNOLOGY FOR ENERGY SYSTEMS

L T P C
3 0 0 3

COURSE OUTCOMES

Upon completion of this course, the students will be able to

- CO 1 : realize the basic working principles of Generators.(K3)
- CO 2 : classify the various types of Energy Saving Methods and storage concepts of electricity (K3)
- CO 3 : familiarize with the concepts of Electricity Transmission & Distribution (K3)
- CO 4 : recognize the concepts of Wheeling and Power Evacuation of Wind & Solar power (K4)

UNIT I GENERATION OF ELECTRICAL ENERGY 9

Sources of Electrical Energy - Working Principle of Generator - Classification of A.C and D.C Generators – Energy requirements – Maximum Demand – Types of Electrical load - Energy Savings in three phase Induction motor.

UNIT II ELECTRICAL ENERGY STORAGE 9

Introduction to Electrical Energy storage - Types of storage – Electrical Storage – Batteries – Types – Selection of Batteries - Capacitor – Super capacitors. Sine wave Inverter

UNIT III ELECTRICITY TRANSMISSION AND DISTRIBUTION 9

Introduction to Transmission – Sub transmission – Types of transmission – Losses in transmission – Control strategies in Grid – Types of grid – Distribution – Types of Distribution - Transformer - Working Principle.

UNIT IV ELECTRICAL SYSTEM FOR WIND ENERGY SYSTEMS 9

Generators for wind energy applications – Types of generators - Grid Connected and self excited Induction Generator – Speed control – Reactive Power Compensation.

UNIT V ELECTRICAL SYSTEM FOR SOLAR ENERGY SYSTEMS 9

Introduction – Balance of System – Tracking – Types of tracking – MPPT - Converter – Standalone System – Grid-Tied System – Data monitoring – Types - Remote – On-site monitoring

L: 45 TOTAL: 45 PERIODS

REFERENCES

1. B.L.Thereja “ A Textbook of Electrical Technology”, 25th Edition S Chand Publishers, 2008
2. S.N.Bhadra, D.Kastha and S. Banerjee, “Wind electrical systems”, Oxford University Press, 2005
3. Chetan Singh Solanki “Solar Photovoltaic Technology and systems”, Prentice Hall of India, 2013
4. C.L. Wadhwa “Generation Distribution and Utilization of Electrical Energy” Revised Edition New Age International 2005.
5. H.A. Kiehne “Battery Technology Handbook” 2nd Edition, Taylor & Francis
6. B.R.Gupta “Generation of Electrical Energy” Tenth Edition, S.Chand and Company Limited, 2011.

15EN02E THERMAL ENERGY SYSTEMS FOR ELECTRICAL ENGINEERS L T P C
3 0 0 3

COURSE OUTCOMES

Upon completion of this course, the students will be able to

- CO 1 : describe the fluid properties and concepts of fluid Mechanics (K2, A1)
- CO 2 : explain the basic concepts and laws of thermodynamics (K2, A1)
- CO 3 : apply the properties of steam in the analysis of steam power cycles (K3, A2)
- CO 4 : discuss the working principles of various compressors, refrigeration and air-conditioning systems (K2, A1)

UNIT I BASIC CONCEPTS OF FLUID MECHANICS 9

Properties of fluids – capillarity and surface tension. Types of Flow, Continuity equation, Euler's equation, Bernoulli's equation – applications - Venturi meter, Orifice meter, Pitot tube - Laminar flow through circular conduits and circular annuli, Hydraulic and energy gradient. Darcy – Weisbach equation. Minor losses - Flow through pipes in series and in parallel.

UNIT II BASIC CONCEPTS AND LAWS OF THERMODYNAMICS 9

Thermodynamic systems – Control volume - System and surroundings – Universe – Properties - State-process – Cycle – Equilibrium - Work and heat transfer – Point and path functions - First law of thermodynamics for open and closed systems - First law applied to a control volume - SFEE equations [steady flow energy equation] - Second law of thermodynamics - Heat engines - Refrigerators and heat pumps - Carnot cycle - Carnot theorem.

UNIT III STEAM BOILERS AND TURBINES 9

Formation of steam - Properties of steam – Use of steam tables and charts – Steam power cycle (Rankine) - Deviation of Actual Vapor Power Cycles from Idealized Ones, Reheat cycle, Regenerative cycle

UNIT IV COMPRESSORS 9

Positive displacement compressors – Reciprocating compressors – Indicated power – Clearance volume – Various efficiencies – Clearance ratio - Volume rate - Conditions for perfect and imperfect intercooling - Multi stage with intercooling – Rotary positive displacement compressors – Construction and working principle of centrifugal and axial flow compressors. Selection of compressors for a particular application.

UNIT V REFRIGERATION AND AIR CONDITIONING 9

Refrigeration - Various methods of producing refrigerating effects (RE) – Vapour compression cycle: P-H and T-S diagram - Saturation cycles - Effect of subcooling and super heating – Other Refrigeration Systems (Qualitative treatment only)
Air-conditioning systems – Basic psychrometry - Simple psychrometric processes - Types of airconditioning systems - Selection criteria for a particular application (qualitative treatment only).

L:45 TOTAL: 45 PERIODS

REFERENCES

1. R.S.Khurmi & J.K.Gupta, "Thermal Engineering", S.Chand & Company Limited, 2006.
2. S.Domkundwar, C.P.Kothandaraman & A.V.Domkundwar, "Thermal Engineering", Dhanpat Rai & Company, 2002.
3. Rogers and Mayhew, "Engineering Thermodynamics – Work and Heat Transfer", Pearson Education Private Limited, New Delhi, 2006.
4. Eastop and McConkey, "Applied Thermodynamics", Pearson Education Private Limited, New Delhi, 2002.
5. P.K.Nag, "Engineering Thermodynamics" Tata McGraw Hill, New Delhi, 2003.
6. Rajput, B.K. Sankar, "Thermal Engineering", S.Chand & Company Limited, 2003.
7. Modi and Seth, "Hydraulics and Fluid Mechanics Including Hydraulics Machines" 20th Edition, Standard Book House, 2013

15EN03E

ADVANCED POWER PLANT ENGINEERING

L T P C
3 0 0 3

COURSE OUTCOMES

Upon completion of this course, the students will be able to

CO 1: analyze the steam and gas power cycles and its possible improvements. (K4, A2)

CO 2: realize the advances in hydro, nuclear and MHD power plants. (K2, A1)

CO 3: identify the economic feasibility and issues related to the power plants. (K2, A1)

UNIT I ANALYSIS OF STEAM POWER PLANTS (SPP) 9

Components of steam power plants, typical layout, Rankine Cycle – performance - energy analysis of Rankine cycle - cycle improvements – Ideal reheat Rankine cycle - The Ideal Regenerative Rankine Cycle - Open Feedwater Heaters - Closed Feedwater Heaters

UNIT II ANALYSIS OF HYDROELECTRIC POWER PLANTS (HEPP) 9

Components of HEPP, typical layout, Classification of Hydraulic Turbines - Pelton, Francis, Kaplan, Propeller, Deriaz and Bulb turbines – specific speed – hydraulic efficiency and comparison - Performance of turbines – Constant head characteristics, Constant speed characteristics and Constant efficiency curves.

UNIT III ANALYSIS OF GAS TURBINE POWER PLANTS 9

Gas turbine cycles – optimization – thermodynamic analysis of cycles – cycle improvements - Intercoolers, reheaters, regenerators - operation and performance – layouts - comparison with other types of power plants.

UNIT IV NUCLEAR AND MHD POWER PLANTS 9

Overview of Nuclear power plants - radioactivity - fission process- reaction rates - elastic scattering and slowing down - criticality calculations – critical heat flux - power reactors - nuclear safety. MHD and MHD - steam power plants.

UNIT V ECONOMIC ASPECTS OF POWER PLANT OPERATION 9

Load curves, load factor, diversity factors and their significance, Economic scheduling of power stations. Interest and depreciation, Costs of electrical energy, Methods of determining depreciation Tariff, characteristics and types of tariff. Economic efficiency - Payback period and Net-present value methods to assess financial efficiency of power plants.

L: 45 TOTAL: 45 PERIODS

REFERENCES

1. Nag, P.K., "Power Plant Engineering", 3rd Edition, Tata McGraw-Hill Education, 2008.
2. Arora and Domkundwar, "A course in Power Plant Engineering", Dhanpat Rai and CO, 2004.
3. Philip Kiameh., "Power generation handbook", Tata McGraw-Hill, 2004
4. Stan Kaplan, "Power Plant Characteristics and Costs", Nova Science Publishers, Inc., 2010
5. R.K. Rajput , "A Textbook of Power Plant Engineering", Laxmi Publications, 2005

15EN04E

ADVANCED THERMAL STORAGE TECHNOLOGIES

L T P C
3 0 0 3

COURSE OUTCOMES

Upon completion of this course, the students will be able to

CO 1: familiarize with the various types of thermal storage systems and the storage materials (K2, A2)

CO 2: develop the model and analyze the sensible and latent heat storage units (K4,A3)

CO 3: recognize various applications of thermal storage systems (K2, A2)

UNIT I INTRODUCTION

9

Necessity of thermal storage – types-energy storage devices – comparison of energy storage technologies - seasonal thermal energy storage - storage materials.

UNIT II SENSIBLE HEAT STORAGE SYSTEM

9

Basic concepts and modeling of heat storage units - modeling of simple water and rock bed storage system – pressurized water storage system for power plant applications – packed beds.

UNIT III REGENERATORS

9

Parallel flow and counter flow regenerators – finite conductivity model – non – linear model – transient performance – step changes in inlet gas temperature – step changes in gas flow rate – parameterization of transient response – heat storage exchangers.

UNIT IV LATENT HEAT STORAGE SYSTEMS

9

Modeling of phase change problems – temperature based model - enthalpy model - porous medium approach - conduction dominated phase change – convection dominated phase change.

UNIT V APPLICATIONS

9

Specific areas of application of energy storage – food preservation – waste heat recovery – solar energy storage – green house heating – power plant applications – drying and heating for process industries.

L: 45 TOTAL: 45 PERIODS

REFERENCES

1. Ibrahim Dincer and Mark A. Rosen, “Thermal Energy Storage Systems and Applications”, John Wiley & Sons 2010.
2. A Thumann, D. Paul Mehta, “Handbook of energy engineering“, 6th Edition, The Fairmont Press, Inc., 2008
3. Halime Ö Paksoy, “Thermal energy storage for sustainable energy consumption”, Springer, 2007
4. IEEE Journals for “Power, Energy & Industry Applications”

15EN05E

ADVANCES IN METALLURGICAL ENGINEERING

L T P C
3 0 0 3

COURSE OUTCOMES

Upon completion of this course, the students will be able to

- CO 1: apply the concepts and principles in materials and engineering in the development and design of new product, to ensure quality assurance in the practice of material engineering. (K3)
- CO 2: characterize the synthesized materials. (K2)
- CO 3: gain fundamental understanding of electrical conduction (transport) in solids, major properties of bulk and nanostructured superconductors. (K2)
- CO 4: create a scientific basis to ensure the safe and responsible development of engineered nanoparticles and nanotechnology-based materials and products (K5)

UNIT I ADVANCED MATERIALS AND TOOLS

9

Smart materials, exhibiting ferroelectric, piezoelectric, optoelectric, semiconducting behavior, lasers and optical fibers, photoconductivity and superconductivity, nanomaterials, synthesis, properties and applications.

UNIT II PHYSICAL METHODS FOR CHARACTERIZATION

9

X-ray diffraction, Powder diffraction, Single crystal X-ray diffraction, Electro-optical and related techniques like SEM, TEM, EDS, WDS/EPMA etc.; Spectroscopic techniques - Vibrational, UV-visible and Electron resonance spectroscopies. Thermal analysis (Differential thermal analysis, Thermogravimetric analysis, Differential scanning calorimetry)

UNIT III ELECTRONIC MATERIALS

9

Dielectric properties, Polarization mechanism, Frequency and Temperature effects, Electrical breakdown, Classification of ferroelectric materials, Piezoelectricity, Capacitor dielectric materials, Insulating materials and Pyroelectric materials, ceramic composites as capacitors & sensors.

UNIT IV SUPERCONDUCTIVITY

9

History and background of superconductivity, Superconducting phenomenon, low temperature Superconductors, Bardeen – Cooper and Schrieffer Theory (BCS), Cooper pair, High temperature Superconductivity. Applications of Superconductors.

UNIT V NANOMATERIALS AND NANOTECHNOLOGY

9

Top down and bottom up approaches, classification of nanomaterials, carbon nanotubes (CNT), particulate reinforced metal/ceramic/polymer nanocomposites, Characterization of nanomaterials, Applications of nanotechnology in medicine, automobile sector, Bragg reflector, Butterfly-wings, Different applications.

L: 45 TOTAL: 45 PERIODS

REFERENCES

1. William F. Smith – “Foundation of Materials Science and Engineering”, 2nd Edition, Mc Graw- Hill International Edition, 1993.
2. S. O. Kasap – “Principles of Electronic Materials and Devices”, 2nd Edition, Tata Mc Graw-Hill Publication, 2002.
3. B.D. Cullity, “Elements of X-ray Diffraction (For X-rays) “, 3rd Edition, Prentice-Hall, Upper Saddle River 2001.
4. C.N. Banwell, “Fundamentals of Molecular Spectroscopy“, 4th Edition, Tata McGraw-Hill Education, 1994.
5. Paul Gabbott, “Principles and Applications of Thermal Analysis”, Publisher Wiley-Blackwell, 2007.
6. A.V. Narlikar, “Frontiers in Superconducting Materials”, Editor, A.V. Narlikar, Publisher Springer, ISBN 978-3-540-27294-6.
7. Dieter Vollath, Nanomaterials: “An introduction to synthesis, properties and applications”, Wiley-CVH.
8. Kenneth J. Klabunde, Nanoscale “Materials in Chemistry”, Publisher- Wiley-Interscience.

15EN06E

ALTERNATIVE FUELS

L T P C
3 0 0 3

COURSE OUTCOMES

Upon completion of this course, the students will be able to

- CO 1: get an insight into the availability of petroleum based fuels, their progress and its influence on environment. (K2, A1)
- CO 2: explore the need, production and technology of utilizing different alternative liquid and gaseous fuels for transportation which include alcohol, biodiesel, CNG, LPG, DME, DEE and hydrogen (K2)

UNIT I

OVERVIEW

9

Introduction – Alternative fuels – Potential solid - liquid - and gaseous fuels. – Alcohols – ethanol, methanol, M85, E85 and gasohol – properties – SI engine combustion performance and emission characteristics. Alcohols for CI engine – Alcohol fumigation – Dual fuel injection – Surface ignition and spark ignition- storage, dispensing and safety – material compatibility.

UNIT II

VEGETABLE OILS AND OTHER SIMILAR FUELS DERIVED

9

Vegetable oils- properties – advantages and disadvantages – Biodiesel – trans-esterification - Factors affecting the process – Properties- Biodiesel blends – engine combustion, performance and emission characteristics- material compatibility , other alternative liquid fuels – benzol – acetone – diethyl ether.

UNIT III

NATURAL GAS AND LPG

9

Alternative gaseous fuels – natural gas and LPG – production – properties of natural gas and LPG – CNG conversion kits – Advantages and disadvantages of NG and LPG – comparison of gasoline and LPG – CNG and LPG fuel feed system – LPG & CNG for CI engine – methods of fuel induction engine combustion, performance and emission characteristics.

UNIT IV

HYDROGEN AS ALTERNATIVE FUEL

9

Hydrogen energy – properties, production, thermo- chemical methods – Hydrogen storage – Delivery – conversion – safety – Hydrogen engines, methods of usage in SI and CI engine – Hydrogen injection system – Hydrogen induction in SI engine.

UNIT V

BIOGAS FOR IC ENGINES

9

Biogas – properties – Biogas for running IC engine – Biogas as vehicle fuel – biogas consumption – engine performance and emission- Biomass gasification – producer gas – consumption – dual fuel operation – engine performance and emission.

L: 45 TOTAL: 45 PERIODS

REFERENCES

1. D Tomes, P Lakshmanan., Biofuels: “Global Impact on Renewable Energy, Production Agriculture, and Technological Advancements”, Springer, 2010
2. Ram B. Gupta, “Hydrogen fuel: production, transport, and storage”, CRC Press, 209
3. Ganesan.V, - “Internal Combustion Engines”, Tata McGraw-Hill Education, 2008
4. M.F. Horddeski, “Alternative fuels: the future of hydrogen”, 2nd Edition, The Fairmont Press, Inc., 2008
5. Sunggyu Lee, J. G. Speight, S. K. Loyalka, “Handbook of Alternative Fuel Technologies”, CRC Press, 2007.
6. B. T. Nijaguna, “Biogas Technology”, New Age International, 2006
7. IEEE Journals for “Power, Energy & Industry Applications”

15EN07E

ANALYTICAL CHEMISTRY

L T P C
3 0 0 3

COURSE OUTCOMES

Upon completion of this course, the students will be able to

- CO 1: select a proper chromatographic technique to isolate the compound. (K1)
- CO 2: apply the knowledge in solving problems / tasks in the field of electro analytical chemistry. (K3)
- CO 3: interpret the data and qualitative estimation by wet chemical analysis. (K2)
- CO 4: evaluate and access chemical reaction and kinetic properties between 0-1600°C for compound. (K5)
- CO 5: extend the knowledge of radiochemical analytical technique. (K2)

UNIT I CHROMATOGRAPHIC METHODS 9
Principle – Classification of chromatographic techniques – Technique and applications of paper chromatography – Thin-layer chromatography – HPTLC – Column chromatography – HPLC, GC-MS and its applications.

UNIT II ELECTRO ANALYTICAL TECHNIQUES 9
Conductometry and its applications – Potentiometry – pH metry and ion selective electrodes – Electrogravimetry – Cyclic Voltammetry and its applications – Amperometric titrations and applications.

UNIT III WET CHEMICAL METHODS OF ANALYSIS 9
Principle of volumetric analysis – Neutralization, Complexometric titrations – Precipitation titrations – Redox titrations – Theoretical aspects of titration curves and end point evaluation – Gravimetric analysis.

UNIT IV THERMAL METHODS 9
Principle, theory, instrumentation and applications of thermogravimetry (TGA) – Differential thermal analysis (DTA) – Differential scanning calorimetry (DSC).

UNIT V RADIOCHEMICAL METHODS 9
General theoretical considerations – Special precautions for radiochemical studies – Equipment for measuring radio activity – G.M. Counter– Determination of characteristics of GM counter – Determination of the absorption curve for ^{234}Th – ^{234}Pa sample.

L: 45 TOTAL: 45 PERIODS

REFERENCES

1. B. Sivasankar, "Instrumental Methods of Analysis", Oxford Higher Education, 2012.
2. F. Settle, "Handbook of Instrumental Techniques for Analytical Chemistry", Pearson Education, Singapore, 2004.

15EN08E COGENERATION AND WASTE HEAT RECOVERY SYSTEMS L T P C
3 0 0 3

COURSE OUTCOMES

Upon completion of this course, the students will be able to

- CO 1: realize the importance of cogeneration in improving the overall efficiency and economy and limiting global warming (K3, A2)
- CO 2: analyze the basic energy generation cycles (K4, A3)
- CO 3: interpret the concepts of cogeneration, its types and probable areas of applications (K3, A1)
- CO 4: identify the significance of waste heat recovery systems and carry out its economic analysis (A3, K2)

UNIT I INTRODUCTION 9

Introduction - principles of thermodynamics – cycles - topping - bottoming – combined cycle - organic rankine cycles – performance indices of cogeneration systems – waste heat recovery – sources and types – concept of tri generation.

UNIT II COGENERATION TECHNOLOGIES 9

Configuration and thermodynamic performance – steam turbine cogeneration systems – gas turbine cogeneration systems – reciprocating IC engines cogeneration systems – combined cycles cogeneration systems – advanced cogeneration systems: fuel cell, Stirling engines etc.,

UNIT III ISSUES AND APPLICATIONS OF COGENERATION TECHNOLOGIES 9

Cogeneration plants electrical interconnection issues – utility and cogeneration plant interconnection issues – applications of cogeneration in utility sector – industrial sector – building sector – rural sector – impacts of cogeneration plants – fuel, electricity and environment

UNIT IV WASTE HEAT RECOVERY SYSTEMS 9

Election criteria for waste heat recovery technologies - recuperators - Regenerators - Economizers - plate heat exchangers - thermic fluid heaters - Waste heat boilers classification, location, service conditions, design Considerations - fluidized bed heat exchangers - heat pipe exchangers - heat pumps – sorption systems.

UNIT V ECONOMIC ANALYSIS 9

Investment cost – economic concepts – measures of economic performance – procedure for economic analysis – examples – procedure for optimized system selection and design – load curves - sensitivity analysis – regulatory and financial frame work for cogeneration and waste heat recovery systems.

L: 45 TOTAL: 45 PERIODS

REFERENCES

1. R.Kehlhofer, B. Rukes, F. Hannemann, F. Stirnimann, “Combined-cycle Gas & Steam Turbine Power Plants”, 3rd Edition, PennWell Books, 209.
2. Steve Doty, Wayne C. Turner, “Energy management handbook”, 7th Edition, The Fairmont Press, Inc., 209
3. A.Thumann, D. Paul Mehta, “Handbook of energy engineering”, 6th Edition, The Fairmont Press, Inc., 2008
4. B.F.Kolanowski, “Small-scale cogeneration handbook”, 2nd Edition, Fairmont Press, 2003
5. M.P. Boyce, “Handbook for cogeneration and combined cycle power plants”, ASME Press, 2002
6. EDUCOGEN – “The European Educational tool for cogeneration”, 2nd Edition, 2001

15EN09E

COORDINATION CHEMISTRY

L T P C
3 0 0 3

COURSE OUTCOMES

Upon completion of this course, the students will be able to

- CO 1: elucidate the structure of the coordination compounds. (K5)
- CO 2: apply the theories and identify the nature of hybridization. (K3)
- CO 3: assign term symbols for any transition metal complexes. (K4)
- CO 4: identify the reaction mechanism of metal complexes. (K3)
- CO 5: describe the keyways by which the biological important metal ion catalysis. (K5)

UNIT I NOMENCLATURE OF METAL COMPLEXES 9

Coordination compounds – Nomenclature – Characteristics – Structural isomerism – Stereoisomerism – Optical isomerism – Stability of complexes – Geometry of complexes.

UNIT II THEORIES OF COORDINATION COMPOUNDS 9

Valence bond theory – Electroneutrality principle and back bonding – Crystal field theory (CFT) – Assumptions of CFT theory – Crystal field splitting of *d*-orbitals in different geometries – Octahedral, square planar and tetrahedral complexes – Molecular orbital theory of π -bonding.

UNIT III SPECTRAL TERMS OF METAL COMPLEXES 9

Russell-Saunders state – Quantum numbers – Spin-spin coupling, orbit-orbit coupling and spin-orbit coupling – Orgel diagrams – Tanabe-sugano diagram for d^3 complex – Electronic spectra of d^2 , d^3 , d^4 , d^5 , d^6 , d^7 , d^8 and d^9 complexes – Charge transfer spectra.

UNIT IV REACTIONS OF METAL COMPLEXES 9

Ligand substitution reactions – S_N1 , S_N2 and S_N1CB mechanism – Outer sphere mechanism – Inner sphere mechanism – Trans effect – Theories of trans effect – Applications of trans effect.

UNIT V BIOLOGICAL IMPORTANCE OF METALS 9

Biological importance of transition metals; Biological roles of Mn, Fe, V, Cu, and Zn in proteins and enzymes – Electron transfer reactions in ferredoxins – Catalysis – blue-copper proteins – Metalloenzymes.

L: 45 TOTAL: 45 PERIODS

REFERENCES

1. F.A. Cotton, G. Wilkinson, C.A. Murillo, M. Bochmann, Advanced Inorganic Chemistry, 6th Edition, John Wiley and Sons, 2009.
2. Concise Coordination chemistry. R. Gopalan and V. Ramalingam. Vikas Publishing House Private Limited, 2001.

15EN10E

DESIGN AND OPTIMIZATION OF ENERGY SYSTEMS

L T P C
3 0 0 3

COURSE OUTCOMES

Upon completion of this course, the students will be able to

- CO 1: perform the Simulation and Modeling of typical energy system (K3, A3)
- CO 2: analyse the effect of constraints on the performance of energy systems (K4)
- CO 3: design energy systems and perform Energy-Economic Analysis for typical applications (K4, A3)

UNIT I INTRODUCTION

9

Engineering Design- Design as Part of Engineering Enterprise- Thermal Systems

UNIT II BASIC CONSIDERATIONS IN DESIGN

9

Formulation of the Design Problem- Conceptual Design- Steps in the Design Process- Computer-Aided Design of Thermal Systems- Material Selection

UNIT III MODELING OF THERMAL SYSTEMS

9

Types of Models - Mathematical Modeling - Physical Modeling and Dimensional Analysis - Curve Fitting

UNIT IV ECONOMIC CONSIDERATIONS

9

Introduction - Worth of Money as a Function of Time-Series of Payments - Economic Factor in Design- Application to Thermal Systems

UNIT V OPTIMIZATION

9

Basic Concepts- Optimization Methods- Optimization of Thermal Systems- Practical Aspects in Optimal Design.

L: 45 TOTAL: 45 PERIODS

REFERENCES

1. Jasbir Arora, Introduction to Optimum Design, 3rd Edition, Elsevier Science & Technology, 2011.
2. Stoecker W.F., Design of Thermal Systems, McGraw Hill, 2011.
3. C. Balaji, Essentials of Thermal System Design and Optimization, CRC Press, 2011.
4. William S. Janna, Design of Fluid Thermal Systems, 3rd Edition, Cengage Learning, 2010.
5. Yogesh Jaluria, Design and Optimization of Thermal systems, 2nd Edition, CRC Press, 2007.
6. Kalyanmoy Deb, Optimization for Engineering design: Algorithms and examples, PHI Learning Private Limited, 2004.
7. IEEE Journals for Power, Energy & Industry Applications

15EN11E DESIGN OF HEAT EXCHANGERS L T P C
3 0 0 3

COURSE OUTCOMES

Upon completion of this course, the students will be able to

- CO 1: realize the basic principles of Heat transfer & Heat Exchangers and applications (K2, A2)
- CO 2: classify various types of flows and disturbances (K2)
- CO 3: design Shell& Tube and Double-Pipe Heat Exchanger, Compact and Plate Heat exchanger, Condenser and performance analysis of Cooling Towers (K4, A3)

UNIT I FUNDAMENTALS OF HEAT EXCHANGER 9

Introduction – Modes of Heat transfer - Temperature distribution and its implications types – Heat exchangers – Classification - Regenerators and Recuperators – Analysis of heat exchangers – Logarithmic Mean temperature difference – Number of transfer Units – Applications.

UNIT II FLOW AND STRESS ANALYSIS 9

Flow – types – Disturbances in flow - Effect of turbulence – friction factor – Pressure loss – stress in tubes – Fouling – Process – types of fouling – control strategies - thermal stresses – types - shear stresses

UNIT III DOUBLE PIPE AND SHELL AND TUBE HEAT EXCHANGER 9

Introduction to Double pipe heat exchangers – Types – Bare inner tube – finned inner tube - Design – Applications - Shell and tube heat exchangers - Types – Design – sizing of heat exchangers – Pressure drop calculations - Applications

UNIT IV COMPACT AND PLATE HEAT EXCHANGERS 9

Introduction to Compact and Plate heat exchanger - Types – merits and demerits – design of compact heat exchangers, plate heat exchangers – performance influencing parameters - limitations.

UNIT V CONDENSERS AND COOLING TOWERS 9

Condensers – Types – Shell & tube – Plate condenser - Design - Cooling tower – types – Natural draft – Mechanical draft - performance characteristics – Range and approach of a cooling tower

L: 45 TOTAL: 45 PERIODS

REFERENCES

1. R. W. Serth, “Process heat transfer: principles and applications”, Academic Press, 2007
2. R. K. Shah, D P. Sekulić, “Fundamentals of Heat Exchanger Design”, John Wiley and Sons, 2003
3. Sadik Kakac and Hongtan Liu, “Heat Exchangers Selection, Rating and Thermal Design”, CRC Press, 2002
4. T. Kuppan, “Heat exchanger design handbook”, Marcel Dekker, 2000
5. IEEE Journals for “Power, Energy & Industry Applications”

15EN12E

ENERGY EFFICIENT BUILDINGS

L T P C
3 0 0 3

COURSE OUTCOMES

Upon completion of this course, the students will be able to

- CO 1: describe the basic concepts of building and its environment (K3)
- CO 2: discuss the principle of energy conscious in buildings (K3)
- CO 3: explain the level of human comfort in Green buildings (K2)
- CO 4: acquire the knowledge about the different climatic zones (K4)
- CO 5: summarize the concept of Energy managements in building (K4)

UNIT I GENERAL ASPECTS

9

Introduction - Building Envelope - Building Materials-Indoor Environment. Components of Indoor Environment. Quality of Indoor Environment.

UNIT II ENERGY CONCIOUS IN BUILDINGS

9

Heating concept -Passive Heating - Direct Gain-Indirect Gain- Isolated Gain-Solarium. Cooling concept- Passive Cooling- Ventilation Cooling- Evaporative Cooling- Nocturnal Radiation Cooling- Desiccant Cooling- Earth Coupling- Daylighting-Basic Principles of Daylighting- Daylighting Systems

UNIT III HUMAN COMFORT

9

Human Comfort-Thermal, Visual, Acoustical and Olfactory comfort. Concept of Sol-air temperature and its significance. Ventilation and is significance.

UNIT IV CLIMATE ZONES

9

Introduction - Climatic zones and their characteristics - Factors affecting climate- Implications of climate on building design- Urban climate-Microclimate

UNIT V ENERGY MANAGEMENT SYSTEM

9

Energy Management of Buildings - Energy Audit of Buildings – Energy - Management matrix monitoring and targeting.

L: 45 TOTAL: 45 PERIODS

REFERENCES

1. Hand book on Energy Conscious Buildings (<http://mnre.gov.in/centers/about-sec-2/hand-book-on-energy-conscious-buildings/>)
2. J.K. Nayak and J.A. Prajapati, "Handbook on Energy Conscious Buildings, Solar Energy Control", MNES, 2006.
3. Energy Conservation Building Codes 2006; Bureau of Energy Efficiency.
4. M.S. Sodha, N.K., Bansal, P.K. Bansal, A.Kumar and M.A.S. Malik., "Solar Passive Building, Science and Design", Pergamon Press, 1986.
5. J.Duffie, W. Beckman, "Solar Engineering of Thermal Processes", 4th Edition, Wiley, 2013

15EN13E ENERGY SYSTEM MODELING AND PROJECT MANAGEMENT L T P C
3 0 0 3

COURSE OUTCOMES

Upon completion of this course, the students will be able to

- CO 1: model and simulate energy systems. (K3)
- CO 2: apply new generation optimization techniques for energy system simulation. (K3)
- CO 3: perform economic analysis of various renewable energy systems. (K3)
- CO 4: categorize management strategies for project evaluation. (K4)

UNIT I INTRODUCTION 9

Primary energy analysis - energy balance for closed and control volume systems - applications of energy analysis for selected energy system design - modeling overview - levels and steps in model development - Examples of models – curve fitting and regression analysis

UNIT II MODELING AND SYSTEMS SIMULATION 9

Modeling of energy systems – heat exchanger - solar collectors – distillation - rectification turbo machinery components - refrigeration systems - information flow diagram - solution of set of nonlinear algebraic equations - successive substitution - Newton Raphson method - examples of energy systems simulation

UNIT III OPTIMISATION TECHNIQUES 9

Objectives - constraints, problem formulation - unconstrained problems - necessary and sufficiency Conditions. Constrained optimization - Lagrange multipliers, constrained variations, Linear Programming - Simplex tableau, pivoting, sensitivity analysis - New generation optimization Techniques – Genetic algorithm and simulated annealing – examples

UNIT IV ECONOMIC ANALYSIS 9

Economics of Standalone Power Supply Systems: Solar Energy - Biomass Energy - Wind Energy and other Renewable Sources of Energy - Economics of Waste Heat Recovery and Cogeneration - Energy Conservation Economics.

UNIT V PROJECT MANAGEMENT 9

Project Management - Financial Accounting: Cost Analysis - Budgetary Control - Financial Management - Techniques for Project Evaluation.

L: 45 TOTAL 45 PERIODS

REFERENCES

1. Stoecker W.F., “Design of Thermal Systems”, McGraw Hill, 2011.
2. D.H. Fredrick and J.C.Newell, C.M .Close, “Modeling and analysis of dynamic systems”, John Wiley & Sons, 2002
3. J.Duffie and W. Beckman “Solar Engineering of Thermal Processes” 4th Edition, Wiley, 2013
4. Singiresu S. Rao, “Applied Numerical Methods for Engineers and Scientists”, Prentice Hall, Upper Saddle River, NJ, 2001.

15EN14E

FLUIDIZED BED SYSTEMS

L T P C

3 0 0 3

COURSE OUTCOMES

Upon completion of this course, the students will be able to

CO 1: comprehend the concepts of fluidization and heat transfer in fluidized beds. (K4)

CO 2: recognize the design principles and apply the same for industrial applications.(K4)

UNIT I FLUIDIZED BED BEHAVIOUR 9

Characterization of bed particles - comparison of different methods of gas – solid contacts. Fluidization phenomena - regimes of fluidization – bed pressure drop curve. Two phase and well-mixed theory of fluidization. Particle entrainment and elutriation – unique features of circulating fluidized beds.

UNIT II HEAT TRANSFER 9

Different modes of heat transfer in fluidized bed – bed to wall heat transfer – gas to solid heat transfer – radiant heat transfer – heat transfer to immersed surfaces. Methods for improvement – external heat exchangers – heat transfer and part load operations.

UNIT III COMBUSTION AND GASIFICATION 9

Fluidized bed combustion and gasification – stages of combustion of particles – performance - start-up methods. Pressurized fluidized beds.

UNIT IV DESIGN CONSIDERATIONS 9

Design of distributors – stoichiometric calculations – heat and mass balance – furnace design – design of heating surfaces – gas solid separators.

UNIT V INDUSTRIAL APPLICATIONS 9

Physical operations like transportation, mixing of fine powders, heat exchange, coating, drying and sizing. Cracking and reforming of hydrocarbons, carbonization, combustion and gasification. Sulphur retention and oxides of nitrogen emission control.

L: 45 TOTAL: 45 PERIODS

REFERENCES

1. Prabir Basu., “Combustion and gasification in fluidized beds”, CRC/Taylor & Francis, 2006
2. Simeon Oka, E. J. Anthony, “Fluidized bed combustion”, M. Dekker, 2004
3. Wen-ching Yang, “Handbook of fluidization and fluid-particle systems”, Marcel Dekker, 2003
4. C. K. Gupta, D. Sathiyamoorthy, “Fluid bed technology in materials processing”, CRC Press, 1999
5. Otto Molerus, Karl-Ernst Wirth, “Heat transfer in fluidized beds”, Springer, 1997

15EN15E

FUEL CELLS AND HYDROGEN ENERGY

L T P C
3 0 0 3

COURSE OUTCOMES

Upon completion of this course, the students will be able to

CO 1: identify hydrogen production methodologies, possible applications and various storage options(K3)

CO 2: converse about the working of a typical fuel cell, its types and to elaborate on its thermodynamics and kinetics(K2)

CO 3: analyze the cost effectiveness and eco-friendliness of Fuel Cells (K4)

UNIT I FUEL CELL BASICS

9

Fuel cell definition, Difference between batteries and fuel cells, fuel cell history, components of fuel cells, principle of working of fuel cells Fuel cell thermodynamics - second law analysis of fuel cells, efficiency of fuel cells fuel cell electrochemistry - Nernst equation, Electrochemical kinetics, Butler-Volmer equation

UNIT II FUEL CELL TYPES

9

Classification by operating temperature/electrolyte type, Fuel Cell Performance, Activation, Ohmic and Concentration over potential

UNIT III FUEL CELL DESIGN AND COMPONENTS

9

Cell components, stack components, system components Overview of intermediate/high temperature fuel cells - Solid oxide fuel cells (SOFC), Molten carbonate fuel cells (MCFC), Phosphoric acid fuel cells (PAFC) Polymer Electrolyte fuel cells ,Heat and mass transfer in polymer electrolyte fuel cells, water management in PEFCs, Current issues in PEFCs, Direct methanol fuel cells (DMFC) - Electrochemical kinetics methanol oxidation, Current issues in MFCs, Fuel crossover in DMFCs, Water management in DMFCs, high methanol concentration operation, limiting current density

UNIT IV HYDROGEN PRODUCTION METHODS

9

Production of hydrogen from fossil fuels, electrolysis, thermal decomposition, photochemical and photo-catalytic methods.

UNIT V HYDROGEN STORAGE METHODS

9

Metal hydrides, metallic alloy hydrides, carbon nano-tubes, sea as source of deuterium.

L: 45 TOTAL: 45 PERIODS

REFERENCES

1. A Faghri and Y Zhang, "Transport Phenomena in Multiphase Systems", Elsevier 2006
2. S Srinivasan, "Fuel Cells: From Fundamentals to Applications", Springer 2006
3. O'Hayre, SW Cha, W Colella and FB Prinz, "Fuel Cell Fundamentals", Wiley, 2005
4. Xianguo Li, "Principles of Fuel Cells", Taylor and Francis, 2005
5. J Larminie and A Dicks, "Fuel Cell Systems Explained, 2nd Edition", Wiley,2003
6. IEEE Journals for "Power, Energy & Industry Applications"

15EN16E

HYDRO POWER TECHNOLOGY

L T P C
3 0 0 3

COURSE OUTCOMES

Upon completion of this course, the students will be able to

- CO 1: reveal the basic concepts of aerodynamics, horizontal and vertical axis wind turbines, small hydro system components (K2, A1)
- CO 2: design and develop prototype systems (K4, A3)
- CO 3: select and analyze the particular turbine for specific need (K4, A2)

UNIT I HYDROLOGY

9

Overview of Hydropower systems-Preliminary Investigation- Rainfall and Run of measurements- Hydrographs- flow duration graph and mass storage graphs- Determination of site selection- types hydro electric power plants- General arrangements and Layouts- Preparation of Reports and Estimates-Review of World Resources-Basic Factors in Economic Analysis of Hydropower projects-Project Feasibility-Load Prediction and Planned Development.

UNIT II DEVELOPMENT OF PROTO TYPE SYSTEMS

9

Advances in Planning, Design and Construction of Hydroelectric Power Stations-Trends in Development of Generating Plant and Machinery-Plant Equipment for pumped Storage Schemes-Some aspects of Management and Operations-Updating and Refurbishing of Turbines-Case Studies

UNIT III SELECTION AND ANALYSIS OF TURBINES

9

Measurement of pressure head, Velocity- Various parameters for finding out the potential of Hydro Energy- Selection of turbines based on Specific quantities- Performance characteristics – Testing of hydraulic turbines - Governing of Impulse and reaction turbines.

UNIT IV HYDRO POWER STATION OPERATION, MAINTENANCE AND TROUBLE SHOOTING

9

Governing of Power Turbines - Functions of Turbine Governor - Condition for Governor Stability- Surge Tank Oscillation and Speed Regulative Problem of Turbine Governing in Future Planning, Design and Construction of Hydroelectric Power Stations - Remaining Lifecycle Analysis.

UNIT V SMALL, MINI AND MICRO HYDRO POWER PLANTS TURBINES

9

Introduction – Analysis of Small, mini and micro hydro turbines – Economical and Electrical Aspects of Small, mini and micro hydro turbines- potential developments – Design and reliability of Small, mini and micro hydro turbines – Case Study. A compulsory Seminar/ Assignment on Design/Case Study/Analysis/Application in any one the Small, Mini and Micro Hydro Power Plants and Components (viz..Turbines, Controls, and Storage etc.)

L:45 TOTAL: 45 PERIODS

REFERENCES

1. P.K Nag ,”Power plant Engineering”, Tata McGraw-Hill Education, 2008
2. A.K.Raja, Amit Prakash Srivastava, “Power Plant Engineering”, New Age International, 2007
3. Finn R. Førsund , “Hydropower Economics”, Springer, 2007
4. Scott Davis,” Microhydro: Clean Power from water”, New Society Publishers, 2004.

15EN17E

MATERIAL SCIENCES AND ENGINEERING

L T P C
3 0 0 3

COURSE OUTCOMES

Upon completion of this course, the students will be able to

CO 1: select advanced materials for various engineering applications. (K2)

CO 2: analyze the crystal structure by knowing the bonding of materials. (K4)

CO 3: interpret the magnetic, electrical and thermal properties of materials. (K2)

UNIT I ADVANCED MATERIALS

9

Materials and Engineering, Types of materials - Metallic materials - Dual phase steels, High strength low alloy (HSLA) steel, Transformation induced plasticity (TRIP) Steel,- Advanced structural ceramics, WC, TiC, Al₂O₃, SiC, Si₃N₄, and diamond –properties, processing and applications - Future trends in materials usage

UNIT II ATOMIC STRUCTURE AND BONDING

9

Structure of atoms- - Bohr's atomic model-Sommerfeld's extension of atomic structure; Electronic structure - Electronic configuration and Quantum numbers; Shapes of s,p,d,f orbitals - Pauli's exclusion principle - Hund's Rule of maximum multiplicity- Aufbau principle, , Types of atomic and molecular bonding – Octet rule - Primary Bonds - Ionic Bonds, Covalent Bonds, Metallic Bonds - Secondary Bonds - Permanent Dipole Bonds, Fluctuating Dipole Bonds

UNIT III CRYSTAL STRUCTURE AND CRYSTAL GEOMETRY

9

Space lattice, crystal systems and Bravais lattices, principal metallic crystal structures, Miller indices, crystallographic planes and directions, comparisons of principle metallic crystal structures, volume and density calculations, crystal structure analysis.

UNIT IV PHASE DIAGRAM AND PHASE TRANSFORMATION

9

Gibbs phase rule, Binary alloy system, Iron-iron carbide diagram, Heat treatment of steels and other non ferrous materials Solidification, crystalline imperfections and diffusion in solids Electrical, optical and mechanical properties of materials.

UNIT V MAGNETIC PROPERTIES OF THE MATERIALS

9

Magnetic Properties - Definition of Magnetic Properties, Types of magnetic bodies, Diamagnetism and Pascal's Constant, Russell-Saunders or LS Coupling, Multiple width Large compared to kT, Multiple width small compared to kT, Stereo chemical applications of Magnetic Properties of the First Transition Series, Determination of magnetic susceptibility by Gouy's Method, Derivation of Van Vleck formula for Susceptibility.

L: 45 TOTAL: 45 PERIODS

REFERENCES

1. W.D.Callister, Jr., "Materials Science and Engineering", Wiley India Private Limited, 2007
2. G.E.Dieter, "Mechanical Metallurgy", McGraw Hill book Company, UK LTD. London, 1988
3. R.E.Reed-Hill; "Physical Metallurgy Principles" 4th Edition, Cengage Learning, 2003
4. Willam F. Smith, "Foundations of Materials Science and Engineering", 3rd Edition, McGraw-Hill series in materials science, 2003
5. Buschow K.H.J. (Ed.), "Handbook of Magnetic Materials", Amsterdam : Elsevier

15EN18E

MATERIALS FOR ENERGY APPLICATIONS

L T P C
3 0 0 3

COURSE OUTCOMES

Upon completion of this course, the students will be able to

- CO 1: realize the properties and characteristics of materials used in energy applications (K2)
- CO 2: acquire the concepts and technologies for manufacturing the solar cells (K2)
- CO 3: summarize the various heat storage media viz., rock-bed, earth, Aquifers etc. (K2)

UNIT I MATERIALS

9

Glazing materials, Properties and Characteristics of Materials, Reflection from surfaces, Selective Surfaces: Ideal coating characteristics, Types and applications, Anti-reflective coating, Preparation and characterization. Reflecting Surfaces and transparent materials. Types of Insulation and properties.

UNIT II PHYSICS OF SOLAR CELLS

9

Intrinsic, extrinsic and compound semiconductors, Electrical conductivity, Density of electrons and holes, Carrier transport: Drift, diffusion, Absorption of light, Recombination process, Materials for Photovoltaic's Conversion, Si and Non-Si materials, crystalline, semi-crystalline, Polycrystalline and Amorphous materials, p-n junction: homo and hetero junctions, Metal-semiconductor interface

UNIT III TECHNOLOGY FOR SI EXTRACTION

9

Purification, Method of doping and junction fabrication, Cell fabrication and metallization techniques: Preparation of metallurgical, electronic and solar grade Silicon, Production of single crystal Silicon: Procedure of masking, photolithography and etching, Design of complete silicon, GaAs, InP solar cell.

UNIT IV SENSIBLE HEAT STORAGE MATERIALS

9

Stratified storage systems, Rock-bed storage systems, Thermal storage in buildings, Earth storage, Energy storage in aquifers, Heat storage in SHS systems, Aquifers storage.

UNIT V PHASE CHANGE MATERIALS, PIEZOELECTRICITY AND FERRO ELECTRICITY

9

Selection criteria of Phase change, Materials use in Solar heating or cooling, Research Status Optical properties, Interaction of solids with radiation, Luminescence, Photoconductivity.

L: 45 TOTAL: 45 PERIODS

REFERENCES

1. Ibrahim Dinçer, Marc Rosen "Thermal Energy Storage", 2nd Edition, John Wiley and Sons, 2010
2. WD Callister, Jr, "Materials Science and Engineering: An Introduction", John Wiley, New York, 2010
3. Robert A. Huggins, "Energy Storage", Springer, 2010
4. Srinivasan, "Engg Materials And Metallurgy", 2nd Edition, Tata McGraw-Hill Education, 2010
5. A Ter-Gazarian, "Energy Storage for Power Systems", Peter Peregrinus Limited, London, 1994
6. R Narayan, B Viswanathan, "Chemical and Electrochemical Energy System", Universities Press, 1998
7. IEEE Journals for "Power, Energy & Industry Applications"

15EN19E

NUCLEAR ENGINEERING

L T P C
3 0 0 3

COURSE OUTCOMES

Upon completion of this course, the students will be able to

CO 1: comprehend the fundamentals of nuclear reactions (K3)

CO 2: infer nuclear fuels cycles, characteristics, fundamental principles governing nuclear fission chain reaction and fusion (K3)

CO 3: develop awareness on future nuclear reactor systems with respect to generation of energy, fuel breeding, incineration of nuclear material and safety. (K4)

UNIT I NUCLEAR REACTIONS

9

Mechanism of nuclear fission - nuclides - radioactivity – decay chains – neutron reactions - the fission process - reactors - types of fast breeding reactor - design and construction of nuclear reactors - heat transfer techniques in nuclear reactors - reactor shielding.

UNIT II REACTOR MATERIALS

9

Nuclear Fuel Cycles - characteristics of nuclear fuels - Uranium - production and purification of Uranium - conversion to UF₄ and UF₆ - other fuels like Zirconium, Thorium - Beryllium.

UNIT III REPROCESSING

9

Nuclear fuel cycles - spent fuel characteristics - role of solvent extraction in reprocessing - solvent extraction equipment.

UNIT IV SEPARATION OF REACTOR PRODUCTS

9

Processes to be considered - 'Fuel Element' dissolution - precipitation process – ion exchange - redox - purex - TTA - chelation -U235 - Hexone - TBP and thorax Processes - oxidative slaging and electro - refining - Isotopes - principles of Isotope separation.

UNIT V WASTE DISPOSAL AND RADIATION PROTECTION

9

Types of nuclear wastes - safety control and pollution control and abatement - international convention on safety aspects - radiation hazards prevention.

L: 45 TOTAL: 45 PERIODS

REFERENCES

1. Raymond LeRoy Murray, "Nuclear energy: an introduction to the concepts, systems, and applications of nuclear processes", 6th Edition, Butterworth-Heinemann, 209
2. John R. Lamarsh, "Introduction to nuclear reactor theory", American Nuclear Society, 2002
3. Glasstone, S. and Sesonske, A, "Nuclear Reactor Engineering", 4th Edition, Springer, 1994.
4. Winterton, R.H.S., "Thermal Design of Nuclear Reactors", Pergamon Press, 1981.

15EN20E

NANOTECHNOLOGY AND NANO ELECTRONICS

L T P C
3 0 0 3

COURSE OUTCOMES

Upon completion of this course, the students will be able to

- CO 1: ensure the safe and responsible development of engineered nanoparticles and nanotechnology based materials and products. (K2)
- CO 2: recognize the risks of nanomaterials for health and the environment (K2)
- CO 3: explore, characterize and evaluate unique nanoscale packaging materials for thin film passive components. (k2)
- CO 4: familiarize with semiconductors and devices including the P-N junction, and the transistors. (k2)

UNIT I FUNDAMENTALS OF SOLID STATE ENGINEERING 9

Future of semiconductor device and research, Applications in food, energy, transportation, communication, entertainment, health and medicine etc. Necessity of innovative technology and prospect for future.

UNIT II CRYSTALLINE PROPERTIES OF SOLID 9

Crystal lattice and seven crystal systems, the unit cell concept, The Weigner-Seitz cell, Bravais lattices, Space and point groups, Miller indices, reciprocal lattice, Brillouin zone.

UNIT III SEMICONDUCTOR HETEROSTRUCTURES AND LOW-DIMENSIONAL QUANTUM STRUCTURES 9

Energy bands, Application of model solid theory, Anderson model for heterojunctions, Multiple quantum wells (MQWs) and super lattices, Two-dimensional nanostructure: quantum well, One-dimensional nanostructure: quantum wire, Zero-dimensional nanostructure: quantum dot, Optical properties of low-dimensional structures, Examples and applications in real world.

UNIT IV FABRICATION OF NANOSTRUCTURES 9

Basic compound semiconductors, Bulk single crystal growth techniques, Epitaxial growth techniques, Physical vapor deposition and sputtering, Thermodynamics and kinetics of growths, Nan scale growth modes

UNIT V CHARACTERIZATION TECHNIQUES 9

Structural, X-ray diffraction, Electron microscopy, Energy dispersive analysis using X-rays, X-ray photoelectron spectroscopy, Secondary ion mass spectroscopy, Rutherford backscattering, Scanning probe microscopy, Optical, Photoluminescence spectroscopy, Absorbance measurement, Raman spectroscopy, Fourier transform spectroscopy.

L: 45 TOTAL: 45 PERIODS

REFERENCES

1. M. Razeghi, "Fundamentals of Solid State Engineering", 2nd Edition, Springer, 2006
2. W. R. Fahrner, "Nanotechnology and Nan electronics: Materials, Devices, Measurement Techniques", Springer-Verlag Berlin Heidelberg, 2005
3. R. W. Kelsall, I. W. Hamley, and M. Geoghegan, "Nanoscale Science and Technology", John Wiley & Sons Limited, England, 2005
4. B.D. Cullity, "Elements of X-ray Diffraction (For X-rays), 3rd Edition"., Prentice-Hall, Upper Saddle River, 2001

15EN21E

PHYSICAL ORGANIC CHEMISTRY

L T P C

3 0 0 3

COURSE OUTCOMES

Upon completion of this course, the students will be able to

- CO 1: draw mechanism, knowledge, reactivity and their structure in various molecular rearrangement. (K3)
- CO 2: recall reagents and predict products for a defined set of organic reactions and to propose mechanism. (K2)
- CO 3: determine the electronic structure of solids and crystal / (dis) order and defects. (K3)
- CO 4: outline the mechanistic aspect for the important photochemical reaction. (K2)
- CO 5: evaluate and choose appropriate reagent for selective functional group transformations and to discuss the mechanism of important organic transformations. (K4)

UNIT I MOLECULAR REARRANGEMENTS 9

Types of rearrangements, Nucleophilic, electrophilic and free radical reactions – Wagner - Meerwein – Pinacol-Pinacolone – Benzil-Benzilic acid – Demjanov – Baeyer Villiger and Curtius rearrangements.

UNIT II NAME REACTIONS 9

Mechanism of the following reactions: Aldol condensation – Perkin reaction – Stobbe condensation – McMurry reaction – Fries rearrangement – Sandmeyer reaction – Schmidt rearrangement – Sonogashira coupling reaction – Kolbe reaction.

UNIT III SOLID STATE 9

Structure of Solids – Crystalline and amorphous solids – Basic crystal systems – Crystal structures of sodium chloride, zinc blende, wurtzite, rutile – Schottky defects – Frenkel defects – Optical and electrical properties of semiconductors – Photovoltaic effect.

UNIT IV PHOTOCHEMISTRY 9

Introduction to photochemical reactions – Cis-trans isomerisation – Paterno-Buchi reaction – Norrish type I & II reaction – Photo reduction of Ketones – Photochemistry of arenes – Barton reaction – Photophysical process.

UNIT V REAGENTS IN ORGANIC SYNTHESIS 9

Reagents for organic synthesis and functional group transformations: Lithium aluminum hydride – Gilman's reagent – Sodiumborohydride – LDA – DCC – Von Rudloff reagent – Lemieux-Johnson reagent – Vaska's catalyst – Wilkinson's catalyst – Ziegler-Natta catalyst.

L: 45 TOTAL: 45 PERIODS

REFERENCES

1. Carey, F.A. & Sundberg, R. J. Advanced Organic Chemistry, Parts A & B, Plenum: U.S, 2004.
2. A.R. West, Solid State Chemistry and its Applications, 2nd Edition, John Wiley & sons, 2014.

15EN22E

SOLAR ARCHITECTURE

L T P C
3 0 0 3

COURSE OUTCOMES

Upon completion of this course, the students will be able to

CO 1: elaborate the current trends in solar architecture and following key concepts:

Solar Passive Architecture and heat transfer in buildings (K3)

CO 2: recognize the Natural Heating/Cooling concepts for Building, Earth to Air Heat exchanger, Thermal Comfort Requirements (K4)

CO 3: outline the concept of Energy Conservation & Concept of Zero Energy Buildings (K2)

UNIT I INTRODUCTION

9

Bio-climatic classification of India, Passive Solar Building and Green Building Concepts, National Building Code, Energy Star Rating, Policies on Energy Efficient and Green buildings.

UNIT II PASSIVE HEATING AND COOLING CONCEPTS

9

Passive heating concepts: Direct heat gain, indirect heat gain, isolated gain and sunspaces, Solar Green Houses, Solar Wall, Solar Trombe wall Evaporative cooling, radiative cooling, Application of wind, water and earth for cooling, Shading, paints and cavity walls for cooling, Roof radiation traps, Earth air-tunnel systems for cooling.

UNIT III THERMAL ANALYSIS AND DESIGN FOR HUMAN COMFORT

9

Thermal comfort, Criteria and various parameters, Psychometric chart, Thermal indices, Climate and comfort zones, Concept of sol-air temperature and its significance, Calculation of instantaneous heat gain through building envelope, Calculation of solar radiation on buildings, Building orientation, Introduction to design of shading devices, Overhangs, Factors that affect energy use in buildings, Ventilation and its significance, Air-conditioning systems.

UNIT IV HEAT TRANSMISSION IN BUILDINGS

9

Surface co-efficient: air cavity, internal and external surfaces, overall thermal transmittance, Wall and windows, Heat transfer due to ventilation/infiltration, internal heat transfer, solar temperature, Decrement factor, Phase lag, Day lighting, Estimation of Building loads: Steady state method, network method, numerical method, correlations.

UNIT V PASSIVE SOLAR DESIGNS OF BUILDING

9

Thumb rules for design of buildings and building codes, Typical design of selected buildings in various climatic zones, Simulation Software's for carrying out thermal design of buildings and predicting performance.

L: 45 TOTAL: 45 PERIODS

REFERENCES

1. David Findley, "Solar Power for Your Home", McGraw-Hill Professional, 2010
2. Jan F. Kreider, P Curtiss, Ari Rabl, "Heating and Cooling of Buildings: Design for Efficiency", 2nd Edition, CRC Press, 2010.
3. Sue Reed, "Energy-Wise Landscape Design", New Society Publishers, 2010
4. S Roaf, M Fuentes, S Thomas, "Ecohouse: a design guide", 3rd Edition, Architectural Press, 2007
5. DS Lal "Climatology", Sharda Pustak Bhawan, Allahabad, 2003
6. Christian Schittich, "Solar architecture: strategies, visions, concepts", Edition Detail, 2003
7. Daniel D. Chiras, "The solar house: passive heating and cooling", Chelsea Green Publishing, 2002
8. IEEE Journals for "Power, Energy & Industry Applications"

**15EN23E SOLAR PHOTOVOLTAIC POWER PLANTS: PLANNING,
DESIGN AND BALANCE OF SYSTEMS**

**L T P C
3 0 0 3**

COURSE OUTCOMES

Upon completion of this course, the students will be able to

- CO 1: describe the physics of photo cells (K3)
- CO 2: compare various technologies along with their pros & cons (K4)
- CO 3: design & analyze on-grid and off-grid PV applications (K4)
- CO 4: realize cost benefit analysis of PV installations (K3)

UNIT I SOLAR CELL FUNDAMENTALS 9

Contribution of Solar PV in Global Energy Scenario – Fundamentals of Semiconductors and Solar cells, Energy band, Charge carriers – Motion, PN Junction diode, Solar cells – Design characteristics, Solar radiation.

UNIT II SOLAR CELL TECHNOLOGIES 9

Silicon cell – Mono crystalline & Multi crystalline – Production, Silicon – Wafer based Solar cell, Thin film solar cells – A-Si, Cd-Te & CIGS, Concentrated PV cells, Emerging technologies – Organic cells, Dye sensitized cells.

UNIT III ON-GRID APPLICATIONS 9

Solar cells to solar array – On-Grid PV system – With & Without storage – Balance of system – DCDC converters – Inverters – Net Metering – Design & analysis – Performance evaluation & monitoring – Field visit – Grid tied PV power plant.

UNIT IV OFF-GRID APPLICATIONS 9

Off-Grid stand alone PV system – System sizing – Module & Battery – Storage – Batteries for PV systems – Sun Tracking mechanism – Types of tracking – One-axis, Two-axis – Maximum power point tracking – Design & analysis – Performance evaluation & monitoring – Field visit – Off-grid PV system.

UNIT V COMMERCIALS FOR SOLAR PV INSTALLATIONS 9

Cost and manufacturability – Cost modeling – Manufacturing economics – scaling – Pricing – Trends in retail pricing – energy economics – grid tied – stand alone applications

L: 45 TOTAL: 45 PERIODS

REFERENCES

1. Chetan Singh Solanki “Solar Photovoltaics Fundamentals, Technologies and applications”, 2nd Edition, Prentice Hall of India, 2012
2. A.K. Mukerjee, Nivedita Thakur “Photovoltaic Systems- Analysis and Design” Prentice Hall of India, 2011
3. Robert Foster Majid Ghassemi, Alma Cota “Solar Energy – Renewable Energy and the Environment”, CRC Press, 2010
4. James P. Dunlop “Photovoltaic Systems”, Second Edition by American Technical Publishers, 209
5. Eduardo Lorenzo “Solar Electricity: Engineering of Photovoltaic Systems” by PROGENSA, 1994
6. www.pveducation.org

15EN24E

SOLAR REFRIGERATION AND AIR-CONDITIONING

L T P C
3 0 0 3

COURSE OUTCOMES

Upon completion of this course, the students will be able to

CO 1: realize the Basic Thermodynamic Modelling, Design Studies and Evaluation methods for Solar Cooling Systems. (K2, A1)

CO 2: familiarize with the economical use of the systems (K2, A1)

UNIT I INTRODUCTION

9

Potential and scope of solar cooling. Types of solar cooling systems, solar collectors and storage systems for solar refrigeration and airconditioning.

UNIT II VAPOUR ABSORPTION AND COMPRESSION REFRIGERATION SYSTEMS

9

Solar operation of vapour absorption – Lithium Bromide –Water Absorption system – Aqua Ammonia Absorption system Intermittent Absorption Refrigeration system – Vapour compression refrigeration cycles and their assessment.

UNIT III THERMODYNAMIC MODELLING

9

Thermal modelling and computer simulation for continuous and intermittent solar refrigeration and airconditioning systems.

UNIT IV SOLAR COOLING SYSTEMS

9

Solar dessicant cooling systems. Open cycle absorption/ desorption solar cooling alternatives. Advanced solar cooling systems. Refrigerant storage for solar absorption cooling systems.

UNIT V ECONOMICS

9

Solar thermoelectric refrigeration and airconditioning. Solar economics of cooling systems.

L: 45 TOTAL: 45 PERIODS

REFERENCES

1. Ursula Eicker, "Low Energy Cooling for Sustainable Buildings", John Wiley and Sons, 2009
2. Hans-Martin Henning, "Solar-assisted air conditioning in buildings: a handbook for planners", Springer, 2007
3. M. Santamouris, D. Asimakopoulos, "Passive cooling of buildings", Earthscan, 1996
4. A. A. M. Sayigh, J. C. McVeigh, "Solar air conditioning and refrigeration", Pergamon Press, 1992
5. IEEE Journals for "Power, Energy & Industry Applications"

15EN25E SPECTROSCOPIC METHODS IN CHEMISTRY

L T P C
3 0 0 3

COURSE OUTCOMES

Upon completion of this course, the students will be able to

- CO 1: elucidate the electronic transition and the effect of conjugation present in the metal complex. (K2)
- CO 2: identify the functional group and vibration of any metal complex. (K2)
- CO 3: predict the splitting pattern and interpret integration of NMR spectra. (K3)
- CO 4: predict the fragmentation pattern to find molecular mass and to identify the structure of a compound. (K3)
- CO 5: interpret experiment spectra and analyzing the results to identify the geometry of the compound. (K2)

UNIT I ULTRAVIOLET SPECTROSCOPY 9

Electronic energy levels – Types of electronic excitations in UV-Vis spectroscopy – Change in position and intensity of absorption – Chromophores and auxochromes – Factors affecting the position of UV bands – Application of UV-Vis spectroscopy to transition metal complexes.

UNIT II INFRARED SPECTROSCOPY 9

Absorption of IR radiation and molecular vibrations – Spectral feature of major functional groups and interpretation of aromatic compounds – Characteristic IR absorption frequencies of important functional groups – Distinction between intermolecular and intramolecular hydrogen bonding – Applications of IR Spectroscopy.

UNIT III NUCLEAR MAGNETIC RESONANCE SPECTROSCOPY 9

Principles of ^1H , ^{13}C NMR – Shielding mechanism – Chemical shift – Spin-Spin coupling – Coupling constants – Splitting of signals – Applications of NMR to organic compounds.

UNIT IV MASS SPECTROMETRY 9

Principle of mass spectrometry – Molecular peak, base peak, isotopic peak, metastable peak and their uses – Mass spectrum of organic compounds – identification – alcohols, aldehydes and aromatic hydrocarbons.

UNIT V ELECTRON SPIN RESONANCE (ESR) SPECTROSCOPY 9

Principle of ESR – Spin-spin relaxation – Hyperfine splitting – Zeeman splitting – g -values – Factors affecting g -value – Determination of g value – Zero field splitting – Application of ESR measurements.

L: 45 TOTAL: 45 PERIODS

REFERENCES

1. Skoog D A, West D M, "Fundamentals of Analytical Chemistry", 8th Edition, Thomson Asia Private Limited, 2004.
2. Jag Mohan, Organic spectroscopy. Narosa Publishing House, New Delhi, 2011.

15EN26E

WASTE MANAGEMENT AND ENERGY RECOVERY

L T P C
3 0 0 3

COURSE OUTCOMES

Upon completion of this course, the students will be able to

CO 1: reveal the various methods of waste management (K2, A1)

CO 2: familiarize with recent energy generation techniques and recent technologies of waste disposal (K2, A1)

CO 3: realize the importance of healthy environment (K2, A1)

UNIT I SOLID WASTE – CHARACTERISTICS AND PERSPECTIVES 9

Definition - types – sources – generation and estimation. Properties: physical, chemical and biological – regulation

UNIT II COLLECTION, TRANSPORTATION AND PROCESSING TECHNIQUES 9

Onsite handling, storage and processing – types of waste collection mechanisms - transfer Stations : types and location – manual component separation – volume reduction : mechanical, thermal – separation : mechanical, magnetic electro mechanical

UNIT III LIQUID WASTE MANAGEMENT 9

Basics, types, working and typical conversion efficiencies of composting – anaerobic digestion – RDF – combustion – incineration – gasification – pyrolysis

UNIT IV HAZARDOUS WASTE MANAGEMENT 9

Hazardous waste – definition - potential sources - waste sources by industry – impacts – waste control methods – transportation regulations - risk assessment - remediation technologies – Private public paternership – Government initiatives.

UNIT V ULTIMATE DISPOSAL 9

Landfill – classification – site selection parameters – design aspects – Leachate control – environmental monitoring system for Land Fill Gases.

L: 45 TOTAL: 45 PERIODS

REFERENCES

1. Michael D. Lagrega., et al., “Hazardous Waste Management”, Waveland Pr Inc, 2010
2. Paul T. Williams, “Waste treatment and disposal”, 2nd Edition, John Wiley and Sons, 2005
3. Velma I. Grover, “Recovering Energy”, Science Publishers, 2002
4. Tchobanoglous, Theisen and Vigil, “Integrated Solid Waste Management”, 2nd Edition, McGraw-Hill, New York, 1993
5. Stanley E. Manahan. “Hazardous Waste Chemistry, Toxicology and Treatment”, Lewis Publishers, Chelsea, Michigan, 1990

15EN27E

RESEARCH METHODOLOGY

L T P C
3 0 0 3

COURSE OUTCOMES

Upon completion of this course, the students will be able to

- CO1: recognize the significances of research. (K2)
- CO2: select the appropriate measurement and scaling technique for the research. (K2)
- CO3: summarize various data collection and analysis. (K2)
- CO4: test the hypothesis relevant to the research work. (K3)
- CO5: document the research findings. (K3)

UNIT I RESEARCH METHODOLOGY: AN INTRODUCTION 9

Research – Objectives, types and significances of Research – Motivations in Research - Importance of Knowing How Research is done – Steps in Research Process - Criteria of Good Research - hurdles in pursuing research

UNIT II MEASUREMENT AND SCALING TECHNIQUES 9

Measurement in Research - Measurement Scales - Sources of Error in Measurement - Tests of Sound Measurement - Technique of Developing Measurement Tools – Scaling - Scale Classification Bases - Important Scaling Techniques - Scale Construction Techniques

UNIT III DATA COLLECTION, PROCESSING AND ANALYSIS OF DATA 9

Collection of Primary Data - Collection of Secondary Data - Selection of Appropriate Method for Data Collection - Processing Operations - Some Problems in Processing - Elements/Types of Analysis - Simple Regression Analysis

UNIT IV TESTING OF HYPOTHESIS 9

Hypotheses - Basic Concepts Concerning Testing of Hypotheses - Procedure for Hypothesis Testing - Measuring the Power of a Hypothesis Test - Tests of Hypotheses - Limitations of the Tests of Hypotheses - Chi-square as a Test for Comparing Variance - Analysis of Variance (ANOVA) Technique - Important Nonparametric or Distribution-free Test

UNIT V INTERPRETATION AND REPORT WRITING 9

Interpretation – Need of Interpretation - Technique of Interpretation - Precaution in Interpretation - Significance of Report Writing - Different Steps in Writing Report - Layout of the Research Report - Types of Reports - Mechanics of Writing a Research Report - Precautions for Writing Research Reports

L: 45 TOTAL: 45 PERIODS

TEXT BOOK

1. C.R.Kothari, “Research Methodology - Methods and Techniques (Second Revised Edition)”, New Age International Publishers, 2004.

REFERENCES

1. Deepak Chawla and Neena Sondhi, “Research Methodology Concepts and Cases”, Vikas Publishing House Pvt Ltd., 2011.
2. R.Panneerselvam, “Research Methodology”, Prentice Hall of India Private Limited, 2014.
3. Pawan Kumar Oberoi, “Research Methodology”, Global Academic Publishers & Distributors, 2015.

15EN28E

DESIGN OF EXPERIMENTS

L T P C
3 0 0 3

COURSE OUTCOMES

Upon completion of this course, the students will be able to

- CO1: describe the statistical process control concepts and implementation. (K2)
- CO2: identify the experimental factors and parameters. (K2)
- CO3: collect data and perform analysis for the experiments. (K2)
- CO4: use various components of design of experiment. (K2)
- CO5: select appropriate method of design of experiment. (K3)

UNIT I DESIGN OF EXPERIMENTS: AN INTRODUCTION 9

Statistical process control and system – Scientific basis for design of experiments – process improvement with Statistical process control – Organizing and implementing industrial experiments.

UNIT II EXPERIMENTAL METHODS 9

Types of experiments – Experimental design factors – Experimental design protocol and examples.

UNIT III DATA COLLECTION AND DATA ANALYSIS FOR DESIGNING EXPERIMENTS 9

Types of data – Data collection – Summarizing Data – Randomization – Replication – Frequency distributions – frequency histograms – scatter diagrams – check sheets – Distribution characteristics – use of standard normal distributions – charts for individual measurements – analyzing control charts

UNIT IV GENERAL METHODS OF DESIGNING EXPERIMENTS 9

ANOVA - Completely Randomized design, Randomized Block design - Two and three factor full Factorial experiments, 2^k factorial Experiments, Confounding and Blocking designs, Fractional factorial design

UNIT V GENERAL APPROACHES IN DESIGNING EXPERIMENTS 9

Taguchi's approach - Steps in experimentation, Design using Orthogonal Arrays, Data Analysis, Robust Design- Control and Noise factors, S/N ratios, Response surface methodology

L: 45 TOTAL: 45 PERIODS

TEXT BOOK

1. Robert F. Brewer, "Design of Experiments for Process Improvement and Quality Assurance" Narosa Publishing House, 2009.

REFERENCES

1. Dieter, George E., "Engineering Design - A Materials and Processing Approach", McGraw Hill, International Editions, Singapore, 2000.
2. Anita Goyal, Karl T Ulrich, Steven D Eppinger, "Product Design and Development", 4th Edition, 2009, Tata McGraw-Hill Education